

tech 1A[®]

Operator's Manual

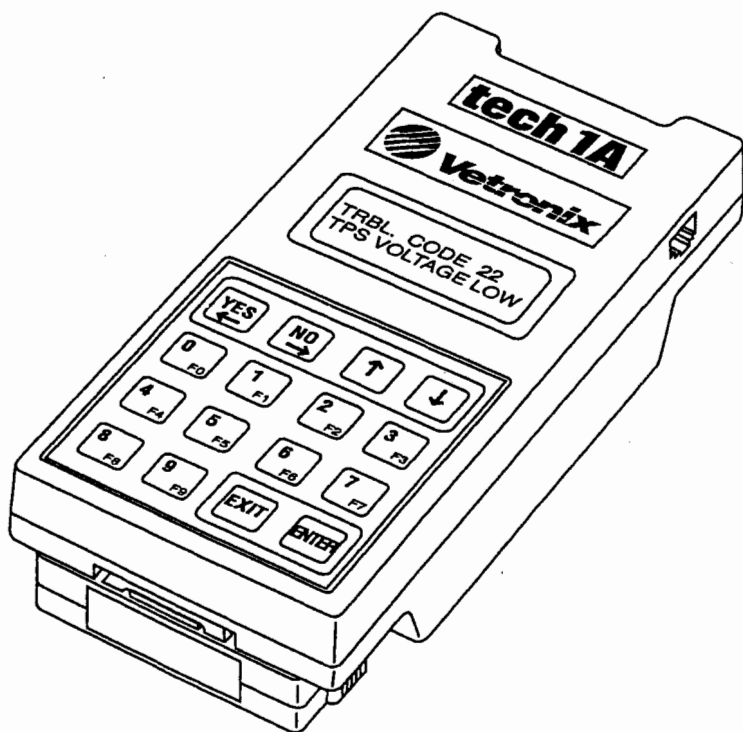

SOME THINGS YOU SHOULD KNOW



CAUTION EXHAUST GAS

When performing any checks with the engine running in an enclosed space such as a garage, be sure there is proper ventilation. Never inhale exhaust gases; they contain carbon monoxide, a colorless, odorless, extremely dangerous gas which can cause unconsciousness or death.



CAUTION

Always set the parking brake securely and block the drive wheels before performing any checks or repairs on the vehicle.

DISCLAIMER

The **TECH 1A** is designed for use by trained service personnel only. It has been developed for the sole purpose of diagnosing and repairing automotive electronic systems. Every attempt has been made to provide complete and accurate technical information based on factory service information available at the time of publication. However, the right is reserved to make changes at any time without notice.

FCC COMPLIANCE

This equipment has been tested and found to comply with the limits for a Class A digital device, pursuant to Part 15 of the FCC Rules. These limits are designed to provide reasonable protection against harmful interference when the equipment is operated in a commercial environment. This equipment generates, uses, and can radiate radio frequency energy and, if not installed and used in accordance with the instruction manual, may cause harmful interference to radio communications. Operation of this equipment in a residential area is likely to cause harmful interference in which case the user will be required to correct the interference at his own expense.

VCCI COMPLIANCE

This device (which should be used in a commercial and industrial area) is made to pass the VCCI standard of whose intention is to provide reasonable protection against harmful interference of electric waves in a commercial and industrial area. It may cause unacceptable interference to receiving devices, such as radios or televisions, if used near them. Please handle it correctly according to the manual.

TABLE OF CONTENTS

SECTION	PAGE
1.0 Getting to know your TECH 1A	1-1
2.0 Getting Started: Connecting the TECH 1A to the Vehicle	2-1
3.0 Operating Precautions	3-1
4.0 Selecting and Operating the RS232 Interface	4-1
Selecting RS232 Compatible Equipment	4-4
RS232 Default Settings	4-5
Setting up the RS232 Modes	4-6
Printer	4-8
Screen Print Mode	4-10
Data List Print Mode	4-15
Terminal	4-20
TECH 1 Display	4-22
Data List Display	4-24
Baud Rate Selection	4-28
5.0 Selecting and Operating Instrumentation Port Functions	5-1
Instrumentation Bus	5-3
Multimeter	5-5
6.0 Finishing Up	6-1
7.0 TECH 1A Specifications	7-1
8.0 Performing the TECH 1A Self-test	8-1
9.0 Warranty and Repair	9-1
APPENDICES	
A. Understanding RS232 Communications	A-1
B. If You're Having a Problem	B-1
C. Glossary and Abbreviations	C-1

1.0 GETTING TO KNOW YOUR TECH 1A

The **TECH 1A** is a handheld Diagnostic Computer designed specifically to help you diagnose and repair automotive electronic control systems. Employing plug-in application cartridges, it can be adapted to operate with virtually all electronic systems from the simplest to the most complex.

The **TECH 1A** gets its power from the vehicle and talks to the vehicle electronic systems via the Data Link Connector (DLC). When connected to the DLC, the **TECH 1A** can readout trouble codes, diagnostic data, and, depending on the application cartridge used, can actually control vehicle systems for trouble-shooting or automatic testing. With its large, sunlight-readable display, the **TECH 1A** tells you in easy to understand language what to do next so you can get started fast using the **TECH 1A** without the need to keep referring to the Operator's Manual. You respond to the **TECH 1A** through the keyboard which commands it to retrieve the diagnostic data that you want, or control the function that you want to control, or conduct the test that you want to run.

The **TECH 1A** uses rugged, plug-in application cartridges to store diagnostic programs that command the **TECH 1A** operation so that your **TECH 1A** can be updated for new vehicles and model years without the need for sending it out of your shop. Also, you can add new application cartridges to your **TECH 1A** for new electronic systems as they are developed, thereby protecting your investment by keeping your **TECH 1A** from becoming obsolete. The **TECH 1A** also has the ability to talk to other devices such as printers, terminals, telephone modems, and even other computers.

The **TECH 1A** has been designed as a rugged shop-ready tool, which will survive years of use due to its sturdy case, sealed keyboard, and heavy-duty cable and connectors. The **TECH 1A** is covered by a twelve month manufacturer's warranty. However, by taking reasonable care of your **TECH 1A** and keeping it in its sturdy storage case when not in use, you can expect years of trouble-free service.

...A DIAGNOSTIC COMPUTER IN YOUR HAND

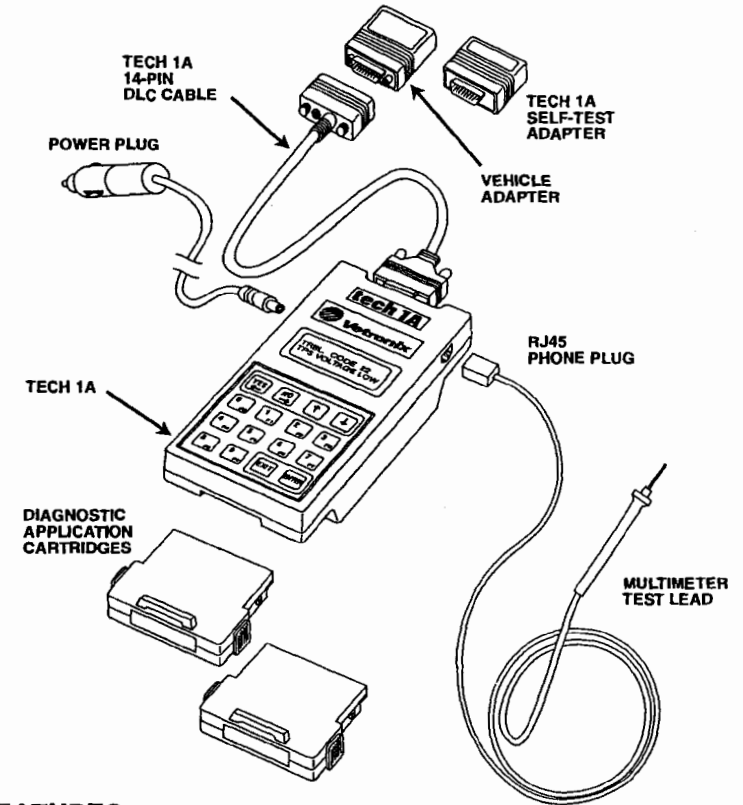

FEATURES

- 4 line, 16 character sunlight readable display, 16 key sealed keyboard
- Diagnostics for advanced Electronic systems
- Plug-in diagnostic application cartridges ensure compatibility with future systems
- Rugged case, heavy-duty cables
- FCC certified
- Built-in Instrumentation Port
- Built-in Self-test capability
- Twelve month manufacturer's warranty
- Built-in RS232 Remote Host Interface
- VCCI certified
- Audio Output (Buzzer)
- 4 channels of 8 Bit A/D Converter Input

TECH 1A TELLS YOU WHAT TO DO ...

The **TECH 1A** has been engineered to allow you to use it with little or no need to refer to an instruction manual. Just plug the **TECH 1A** into the vehicle and watch the **TECH 1A** tell you what to do. If you have a cartridge plugged in, it will tell you which cartridge is plugged in and then display various engines or vehicles that you may want to test. After you select the application, the **TECH 1A** will start collecting data from the vehicle. If you forgot to connect the **TECH 1A** to the vehicle, it will tell you to do so.

When properly connected and operating, the **TECH 1A** will give you a "menu" of tests. Of course the "menu" displayed depends on which type of cartridge you have plugged into the **TECH 1A** but generally the "menu" will include such selections as "Data List", "Vehicle Diagnostics", "Trouble Codes", "Snapshot", and "Miscellaneous Tests". You select the Test Mode by pressing the desired Function key (F-key) and the **TECH 1A** starts operating in that mode. Some modes will operate immediately after being selected, such as Trouble Code Mode, where the trouble codes will be immediately displayed, while others will ask you to select other specific information to begin testing exactly what you want to test. While each cartridge provides a unique set of tests, the general operating procedure for each cartridge has been designed to be about the same to avoid confusion when operating different cartridge types. Every step of the way, the **TECH 1A** offers you selections and it will not proceed until you tell it to do so.

The **TECH 1A** is easy to use so read on for more information on how to get started. You will soon see how easy the **TECH 1A** is to operate and begin to become familiar with its "natural, hand-held feel."

...MAKING OPERATION SIMPLE AND FAST

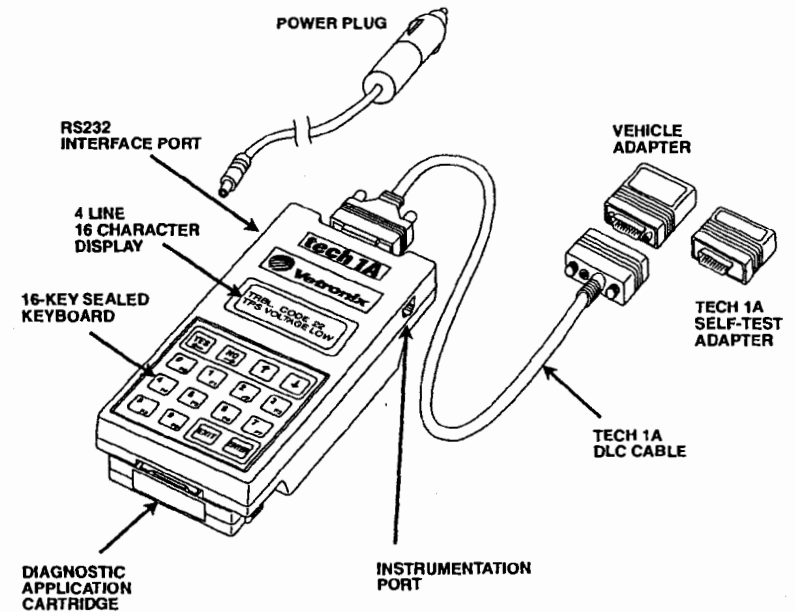

KEYS	TYPICAL FUNCTION
YES , NO or ← , →	Operator response to TECH 1A queries. or Scroll cursor left or right.
↑ , ↓	Scroll display.
0 - 9 or F0 - F9	Input numbers or Command special functions.
ENTER	Enter numbers.
EXIT	Terminate operating modes.

NOTE: Keys 0/F0-9/F9 have a dual purpose: to either enter data which has been asked for or to perform special functions listed in the "menu" display.

JUST SELECT A CARTRIDGE ...

The **TECH 1A** uses pluggable application cartridges to get its instructions that tell it what to do. You simply select the application cartridge to perform the function that you want, plug it in, connect the **TECH 1A** to the vehicle and start testing. There are two types of cartridges: master cartridges which plug into the bottom slot and auxiliary cartridges that plug into the top slot. New cartridges are constantly being developed to provide additional functions. When you acquire new cartridges, detailed operating instruction pages are provided which can be inserted in the appropriate sections of this manual. Storage for up to five cartridges is provided in the **TECH 1A** storage case.

CARTRIDGE INSTALLATION

- 1) Unplug the **TECH 1A** from the vehicle.
- 2) Insert the cartridge into the desired slot while pressing the side tabs. Make sure the retaining hooks snap into place to provide a good, secure mating of the cartridge connector. The cartridge can only be plugged in one way.
- 3) See Section 2 to plug the **TECH 1A** into the vehicle and start testing!

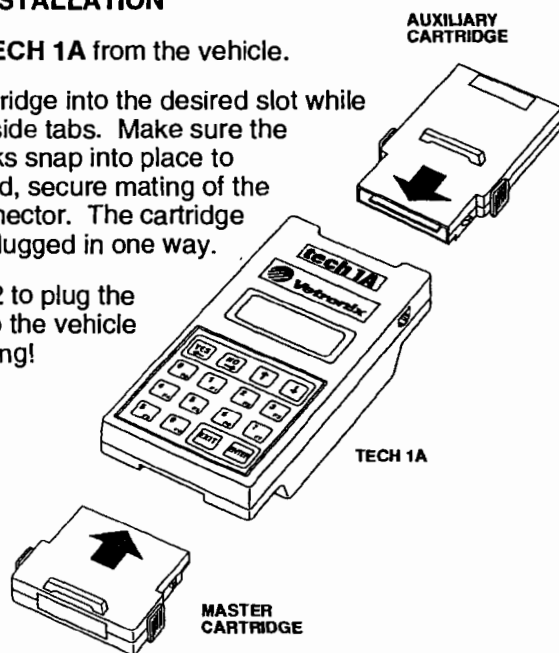

Notice:

1. Keep the cartridge connector tabs and the **TECH 1A** slot connector clean and dry to ensure proper operation.
2. The cartridge connector tab can be cleaned with any non-abrasive cleaner.
3. Avoid spilling fluids into the cartridge or the **TECH 1A** case.

...OR OPERATE THE TECH 1A IN STAND-ALONE MODE...

The **TECH 1A** contains built-in capabilities which allow it to perform unique diagnostic functions. These capabilities include a built-in RS232 interface, which lets you connect the **TECH 1A** to a printer, terminal or host computer, and a built-in Instrumentation Port which supports two modes of operation: Instrumentation Bus and Multimeter.

RS232 INTERFACE

The RS232 Interface allows the **TECH 1A** to transfer and receive data to and from other RS232 compatible devices. The **TECH 1A** can transfer diagnostic data to a printer for a hard copy of test results or to a terminal for a "big screen" display of diagnostic data. Using the RS232, the **TECH 1A** can also transfer and receive data to and from remote host computers including personal computers, computer-based test equipment, and data base computer systems.

INSTRUMENTATION PORT

The **TECH 1A** also acts as a "Diagnostic System Controller" for a complete diagnostic equipment set. Operating as the Instrumentation Bus Controller, the **TECH 1A** can operate with one or more "smart" instrumentation bus devices or test pods to perform vehicle diagnostics with or without serial data input from the vehicle diagnostic data link.

MULTIMETER

Utilizing the Multimeter capabilities of the Instrumentation Port the **TECH 1A** can be used to measure:

- voltage
- frequency
- pulse width
- duty cycle
- period

You simply plug the single test lead provided with the **TECH 1A** into the Instrumentation Port connector and start probing test points on the vehicle to measure critical voltage and timing signals.

...AND BEGIN TESTING ELECTRONIC CONTROLLERS...

After connections are made to a vehicle Data Link Connector (DLC), you can begin testing electronic systems ranging from slow (or fast) data engine controllers to the most advanced brake, body, transmission and air bag systems, depending on which cartridge you have selected.

Select any Master Cartridge, make the proper connections to the vehicle and begin telling the **TECH 1A** the system you want to test. Each Master Cartridge is designed to let you easily choose the test mode for the system you have selected.

After a proper selection, the **TECH 1A** will display a "menu" of tests from which you can select the test that you want to run. Depending on the cartridge selected, some of the options might be:

- readout of trouble codes
- display of diagnostic data in pairs with easy to understand descriptors (in addition to standard data pairs, you can form your own data pairs for displaying)
- snapshot up to 600 samples of diagnostic data when a trouble code is set or when you command a snapshot and read back the data to analyze the problem
- exercise various solenoids and actuators
- enter and operate in special diagnostic modes

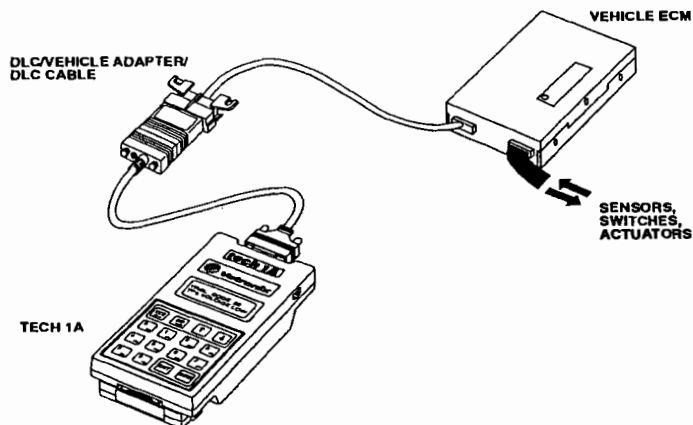

...AND ADVANCED ELECTRONIC SYSTEMS

If you are testing a vehicle with an advanced electronics system, select the cartridge for that system, make the proper connections to the vehicle, and start testing.

For example, if you are testing a 1993 H-Body Buick, select the "88-94 Body Systems" cartridge and you can test up to five on-board computers functioning individually or operating as a total system.

Make the proper connections to the vehicle and the **TECH 1A** will ask you to select the vehicle model that you want to test. After selections, the **TECH 1A** will display the test "menu" and you can select the test that you want to run including:

- readout of Engine Control Module (ECM), Body Computer Module (BCM), or Transmission Control (TCM) trouble codes
- monitor data being transmitted from any vehicle subsystem or send data to any vehicle subsystem
- snapshot up to 600 samples of diagnostic data before and after a trouble code is set in any vehicle subsystem, or you can command a snapshot and then read back the data to analyze the problem
- operate the on-vehicle service diagnostics from the **TECH 1A** in the palm of your hand while you're working on the vehicle. Expanded capabilities are provided such as expanded trouble code descriptors, dual parameter displays, automatic data selection based on trouble codes, readout of EEPROM I.D. and option codes, etc.

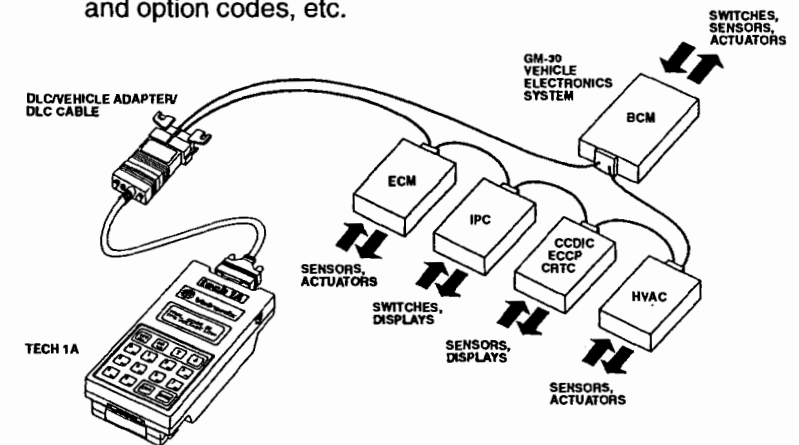

2.0 CONNECTING THE TECH 1A

The **TECH 1A** has four connectors: vehicle interface, RS232 interface, Instrumentation Port, and power input. The basic **TECH 1A** kit includes three cables: 14-pin Data Link Connector (DLC); Instrumentation Port test lead; and DC power cord. The RS232 cable is provided separately with the optional RS232 accessories and an Instrumentation Bus cable is provided separately with the optional instrumentation bus device.

Connecting the **TECH 1A** is simple and fast:

1. Connect the smaller end of the **TECH 1A** DLC cable to the top of the **TECH 1A** and tighten the screws.
2. Attach the adapter for the vehicle you are testing to the larger end of the **TECH 1A** DLC cable.
3. Make sure the vehicle ignition is OFF.
4. If you are using a master cartridge insert it into the Master Cartridge slot on the bottom of the **TECH 1A**. If an auxiliary cartridge is to be used, install it in the Auxiliary Cartridge slot at the top of the **TECH 1A**.
5. Depending on the vehicle being tested, the **TECH 1A** receives its power either directly from the vehicle diagnostic link connector, or by connecting the **TECH 1A** to the vehicle's cigarette lighter socket with the power cord provided in the **TECH 1A** kit.

If the **TECH 1A** is powered by the vehicle's DLC, plug the vehicle adapter on the end of the **TECH 1A** DLC cable into the vehicle's DLC.

If the **TECH 1A** is powered by the vehicle's cigarette lighter, connect the 12V power cord to the left side of the **TECH 1A** or to the larger end of the **TECH 1A** DLC cable, then insert the cigarette lighter plug into the cigarette lighter socket and verify that the correct Power-up screen is displayed (see below). If the **TECH 1A** does not power-up, check the 3 amp fuse in the end of the cigarette lighter plug and replace if necessary. Once the Power-up display is correct, plug the vehicle adapter on the end of the **TECH 1A** DLC cable into the vehicle's DLC.

MASTER CARTRIDGE MODE

If a master cartridge is installed when the **TECH 1A** is powered up, the title screen for the cartridge (as shown in the Cartridge Operator's Manual) should be displayed on the **TECH 1A** screen.

STAND-ALONE MODE

If no master cartridge is installed when the **TECH 1A** is powered up, "MASTER CARTRIDGE MISSING" is displayed for 2 seconds followed by the Onboard Functions menu. If a master cartridge is installed, the Stand-alone mode may be entered by pressing **F6** for approximately 1 second.

*When the **TECH 1A** is operating in Stand-alone mode, the Onboard Functions menu and displays are in English unless you are using a master cartridge that supports **TECH 1A** Onboard Functions in multi-language displays. **TECH 1A** Self-test displays are always in English.*

81-93 POWERTRAIN
(VER 1.1)
SELECT
MODEL YEAR: 19??

Power-up display
with 81-93 Powertrain
Cartridge installed.

F0: RS232
F1: INSTR. BUS
F2: MULTIMETER
F3: SELF-TEST

Onboard Functions Menu
is displayed if no master
cartridge is installed.

If the Power-up menu is correct, proceed to Step 6.

If anything other than the correct Power-up display is visible, or if the screen is blank, see Appendix B.

6. MASTER CARTRIDGE MODE

Turn the ignition ON and, depending on the cartridge being used, the **TECH 1A** will ask you to select a language or the model year of the vehicle you are testing. You are now ready to begin testing.

STAND-ALONE MODE

Attach the appropriate cable and select the function you wish to use.

3.0 OPERATING PRECAUTIONS



CAUTION

Personal injury or damage to the **TECH 1A** may result if the test lead is used to check voltages higher than 30 volts (e.g. standard AC wall outlet). Also, the test lead should be kept away from high tension secondary ignition wires when the engine is cranking or running.

Notice:

CONNECTING AND DISCONNECTING THE **TECH 1A** WHILE THE IGNITION KEY IS ON

Due to the possibility of voltage spikes that could damage the vehicle or **TECH 1A**, you should not connect or disconnect the **TECH 1A** cables while the ignition key is ON or while the engine is running.

REMOVING AND INSTALLING CARTRIDGES WHILE POWER IS APPLIED

You should not remove or install a master or auxiliary cartridge while power is applied to the **TECH 1A**. If you wish to change or add a cartridge:

1. Turn the ignition OFF
2. Disconnect the power source for the **TECH 1A**
3. Change or install cartridge(s)
4. Reconnect the power source
5. Turn the ignition to ON

REMOVING OR CHANGING MASTER CARTRIDGES CONTAINING SNAPSHOT DATA

SNAPSHOT data that has been captured by the **TECH 1A** can be printed on a **TECH 1** (or compatible) printer, transferred to a computer for further analysis, or displayed on a terminal. The SNAPSHOT data will be retained within the **TECH 1A** memory for up to 24 hours, even if the **TECH 1A** is disconnected from the vehicle. However, **IF YOU POWER UP THE TECH 1A WITHOUT A MASTER CARTRIDGE OR WITH A DIFFERENT MASTER CARTRIDGE, THE SNAPSHOT DATA WILL BE LOST.**

4.0 USING THE RS232 INTERFACE

The RS232 interface is a standard for communication between computers and computer peripherals such as printers and display terminals. Used either in conjunction with a master cartridge or in the Stand-alone mode, the built-in RS232 interface provides you with a means of passing information between the **TECH 1A** and an external device.

RS232 compatible equipment may be connected to the **TECH 1A** RS232 interface port via the 10-Pin RJ45 "Phone Plug" connector located on the left side of the **TECH 1A**.

The 10-pin RJ45 connector for RS232 components is "keyed" so that it will fit into the RS232 port on the left side of the **TECH 1A**, but it will not fit into the instrumentation port on the right side. The 8-pin RJ45 connectors supplied with **TECH 1** printer kits may also be used in the RS232 port.

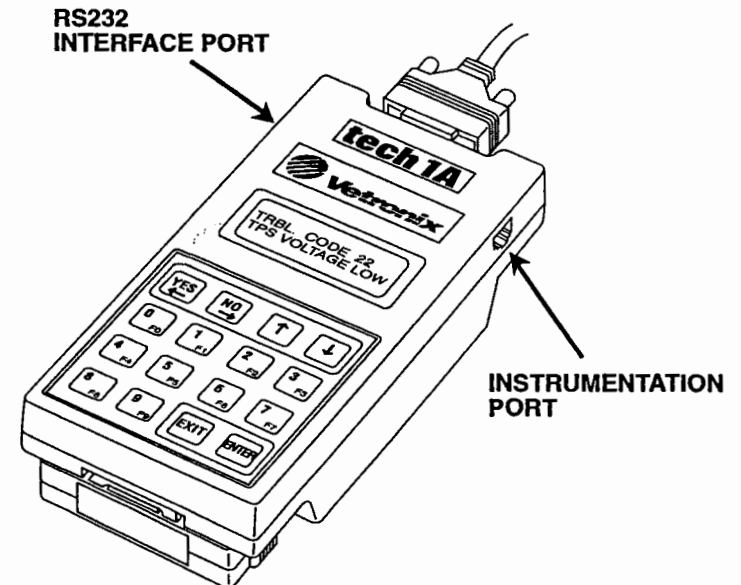

The following list gives you a quick summary of the RS232 modes. Detailed instructions for selecting and operating each RS232 mode is given later in this section.

PRINTER OPERATING MODES

One of the primary uses of the RS232 interface is to enable you to print data captured by the **TECH 1A**. Data List information, Snapshot data, Trouble Codes and vehicle information can be printed. Two printing modes, Screen Print and Data List Print, allow the data to be printed in a variety of formats.

SCREEN PRINT

Automatically prints a copy of the **TECH 1A** screen whenever the displayed data changes.

DATA LIST PRINT

Print the entire Data List or make your own list of parameters to be printed.

OTHER PRINT FUNCTIONS

Some master cartridges provide special print formats which are customized for the data being printed. For example, the master cartridge may print test results in a more readable manner including an identification of the engine and model year. Instructions for using special master cartridge print formats are included in the master cartridge Operator's Manual.

Data collected with auxiliary cartridges can also be printed. An example is the MAF TESTER Cartridge which is used to perform a special test on the vehicle's MAF sensor. Instructions for printing are included in the auxiliary cartridge Operator's Manual.

TERMINAL OPERATING MODES

When the **TECH 1A** is connected to a terminal, the display capability is increased from 64 characters to 2000 characters. This allows you to see much more data at one time and provides you the opportunity to display the data in a variety of formats. The **TECH 1A** offers two Terminal Display modes: **TECH 1** Display and Data List Display.

TECH 1 DISPLAY

Display the **TECH 1A** screen on a remote terminal in double-high, double-wide format.

DATA LIST DISPLAY

Display the entire Data List (up to 50 parameters at a time) in small character format, or select any 12 parameters to display in large character (double-high, double-wide) format.

REMOTE HOST INTERFACE

The RS232 interface provides a means of transferring information between the **TECH 1A** and another computer. This link allows you to collect data with the **TECH 1A**, then transfer the data to the remote computer for storage and detailed analysis. With the **TECH 1A** linked to a remote computer the following functions are available:

- Remote control of the **TECH 1A**
- Real time transfer of vehicle data to the computer system
- Uploading of Snapshot data to the computer system
- Displaying a large number of parameters simultaneously
- Performing analysis of vehicle data
- Saving vehicle data on disk for future evaluation and reference

The transfer of data is initiated and controlled by the remote host, so no set-up is necessary for the **TECH 1A**. Operating instructions for the link between the **TECH 1A** and a host computer are supplied with the software which supports the link.

SELECTING RS232 INTERFACE COMPATIBLE EQUIPMENT

PRINTERS

The RS232 interface supports two types of serial printers: the **TECH 1** printer and an IBM* compatible printer.

TECH 1 PRINTER The **TECH 1** printer is a small portable printer which is capable of being operated using the same 12-volt power source as the **TECH 1A**. The **TECH 1** printer kit contains a Y-Adapter Cable which allows the **TECH 1A** and printer to be powered from a single cigarette lighter. The RS232 print modes support red print (for printing trouble codes) and the double wide print features of the **TECH 1** printer, as well as the printing of a variety of non-standard characters.

IBM COMPATIBLE PRINTER The **TECH 1A** can be set up to print to any IBM compatible serial printer which supports an RS232 interface. Refer to the printer's manual to verify the printer cable is compatible with the RS232 signals.

Most printers used with personal computers are parallel, not serial printers, and will not work with the TECH 1A. If you are planning to use a printer other than the TECH 1 printer, make sure that it supports RS232 serial communications.

TERMINALS

The **TECH 1A** supports the following display terminals: VT-100 (WYSE 60) and VT-220 (WYSE 85). The baud rate for these terminals can be set at 9600 bps to match the default setting for the **TECH 1A**. Terminal performance can be improved by 25-50% by changing the baud rate for both the **TECH 1A** and terminal to 19,200 bps .

*IBM is the registered trademark of International Business Machines Corporation

REMOTE HOST COMPUTERS

Software packages are available that link the **TECH 1A** to computer systems such as:

- GENERAL MOTORS
TECH 15 and GM proprietary computer systems
- SUN ELECTRONIC CORP.
MTT 1800, MCA 3000, MGA 9000
- VETRONIX CORPORATION
TECHVIEW FOR IBM PC (or compatible)

RS232 DEFAULT SETTINGS

Listed below are the devices and operating modes that are automatically selected when the **TECH 1A** is powered up. If the settings don't match the device you are using, or if you wish to select a different device or RS232 mode, see "Setting Up the RS232 Modes" below to display the RS232 Set-up menu.

PRINTER

The RS232 printer mode is initially set up to print the entire Data List on a **TECH 1** printer whenever the **F8** key is pressed while in the Data List or Snapshot mode. To make your own list of parameters to be printed or displayed, the **TECH 1A** must be in the Data List mode or Snapshot mode.

TERMINAL

The RS232 terminal mode is initially set to use a VT-100 (WYSE 60) terminal. To display all Data List parameters, or select specific parameters to display, the **TECH 1A** must be in the Data List or Snapshot mode of operation.

BAUD RATE

The baud rate for the **TECH 1A** and peripheral devices connected to the **TECH 1A** RS232 port must be set at the same rate in order to communicate. If the baud rates don't match, "garbage" will be printed or displayed. The **TECH 1A** baud rate is initially set at 9600 bits/second (bps). If the baud rate of the external device you are using (printer, terminal, etc.) is different, you must change the baud rate of either the **TECH 1A** or the external device.

SETTING-UP THE RS232 MODES

To change the RS232 modes default settings you must enter the RS232 Set-up menu as described below.

When operating the **TECH 1A** with a master cartridge installed, press the **F6** key for one second to display the Onboard Functions menu. From the Onboard Functions menu press **F0** to select the RS232 Set-up menu.

If no master cartridge is installed when the **TECH 1A** is powered-up, the Onboard Functions menu is automatically displayed. Press **F0** to select the RS232 Set-up menu.

From the RS232 Set-up menu you may select:

- The data you wish printed or displayed
- The type of printer and terminal you are using
- The baud rate for the RS232 mode

Once the RS232 default settings have been changed, the **TECH 1A** will retain the new settings for up to 24 hours, or until they are changed again.

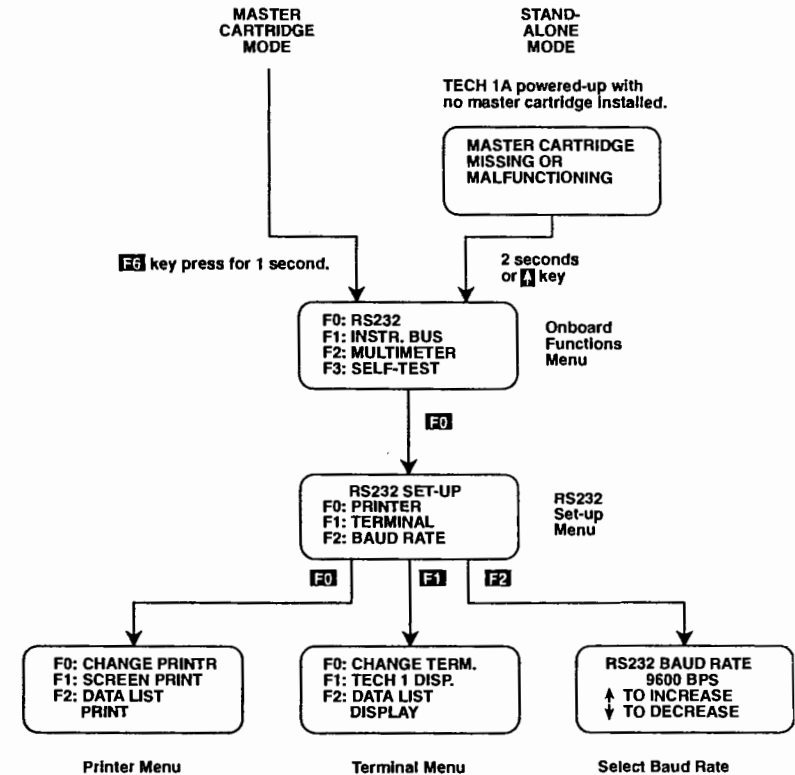

SETTING UP THE RS232 MODES

F2:DATA LIST PRINT and **F2:DATA LIST DISPLAY** are only available when the **TECH 1A** is operating in Data List or Snapshot mode.

F0: PRINTER

F0: CHANGE PRINTER

The RS232 interface supports two types of printers: the **TECH 1** printer or an IBM compatible serial printer. If no printer is selected, the RS232 interface defaults to the **TECH 1** printer. **If you are using a TECH 1 printer, you do not need to perform this function.**

OPERATING PROCEDURE

1. If the **TECH 1A** is operating with a master cartridge installed, press the **F6** key for approximately 1 second to display the Onboard Functions menu.

If the **TECH 1A** is operating in Stand-alone mode, press **EXIT** until the Onboard Functions menu is displayed.
2. From the Onboard Functions menu, press **F0** to reveal the RS232 Set-up menu.
3. From the RS232 Set-up menu press **F0: PRINTER**.
4. Press **F0** to select **CHANGE PRINTER**.
5. Select either **F0: TECH 1 PRINTER** or **F1: IBM COMPATIBLE**.
6. The **TECH 1A** will display the selected printer for 2 seconds before returning to the Printer menu. Pressing **EXIT** before the two seconds is up will also terminate this display and return you to the Printer menu. The **TECH 1A** will remember which printer you selected for up to 24 hours.
7. Press **EXIT** from the Printer menu to return to the RS232 Set-up menu. Press **EXIT** again to return to the Onboard Functions menu. Press **EXIT** again to return to normal **TECH 1A** operation.

F0: PRINTER

F0: CHANGE PRINTER

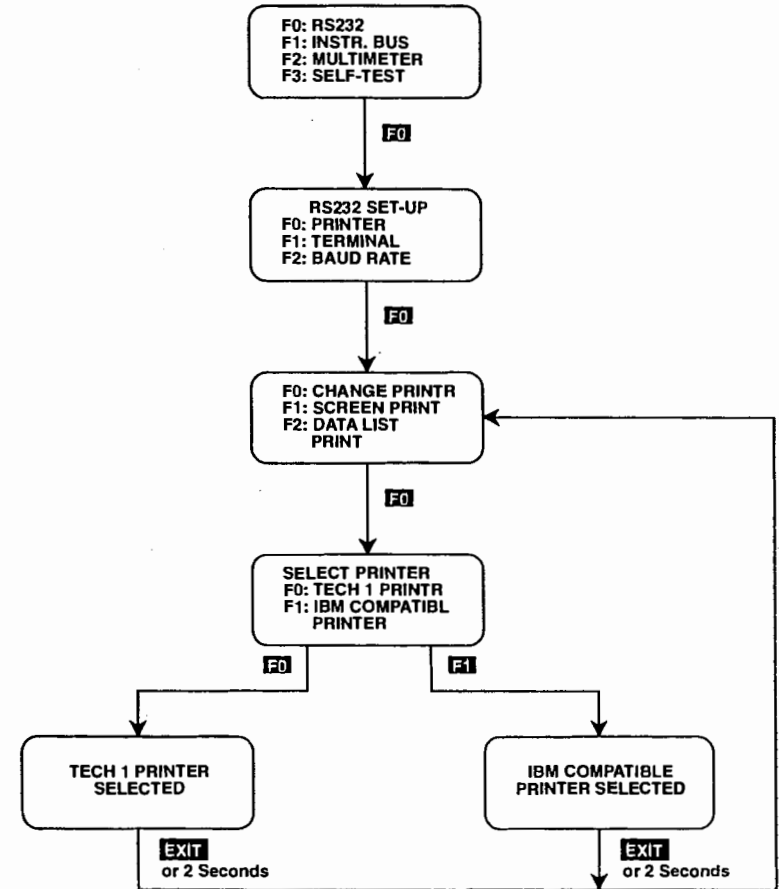

CHANGE PRINTER FUNCTION

F0: PRINTER

F1: SCREEN PRINT

Use F1: SCREEN PRINT to enable and disable the **TECH 1A** SCREEN PRINT function. When Screen Print is enabled, the **TECH 1A** screen is printed when the displayed data changes. See pages 4-12 to 4-14 for a detailed description of the Screen Print mode of printing.

Remember that not all screens displayed on the **TECH 1A** are printed. In general, most of the displays for the set-up procedures and the selection menus are not printed.

OPERATING PROCEDURE

1. If the **TECH 1A** is operating with a master cartridge installed, press the **F6** key for approximately 1 second to display the Onboard Functions menu.

If the **TECH 1A** is operating in Stand-alone mode, press **EXIT** until the Onboard Functions menu is displayed.

2. From the Onboard Functions menu, press **F0** to reveal the RS232 Set-up menu.

3. From the RS232 Set-up menu press **F0** to display the Printer Output menu.

4. Select F1: SCREEN PRINT, then select F0: START PRINT to enable the Screen Print function. If the printer is ready, "SCREEN PRINT ENABLED" is displayed for 2 seconds before the **TECH 1A** returns to normal operation. If the printer is not connected, turned off, not ON LINE, or out of paper, the message "PRINTER IS NOT READY" will be displayed.

5. To turn the Screen Print function OFF, repeat Steps 1-4, then press F1: STOP PRINT. After 2 seconds (or an **EXIT** key press) the **TECH 1A** returns to the Onboard Functions menu. Press **EXIT** again to return to normal **TECH 1A** operation.

F0: PRINTER

F1: SCREEN PRINT

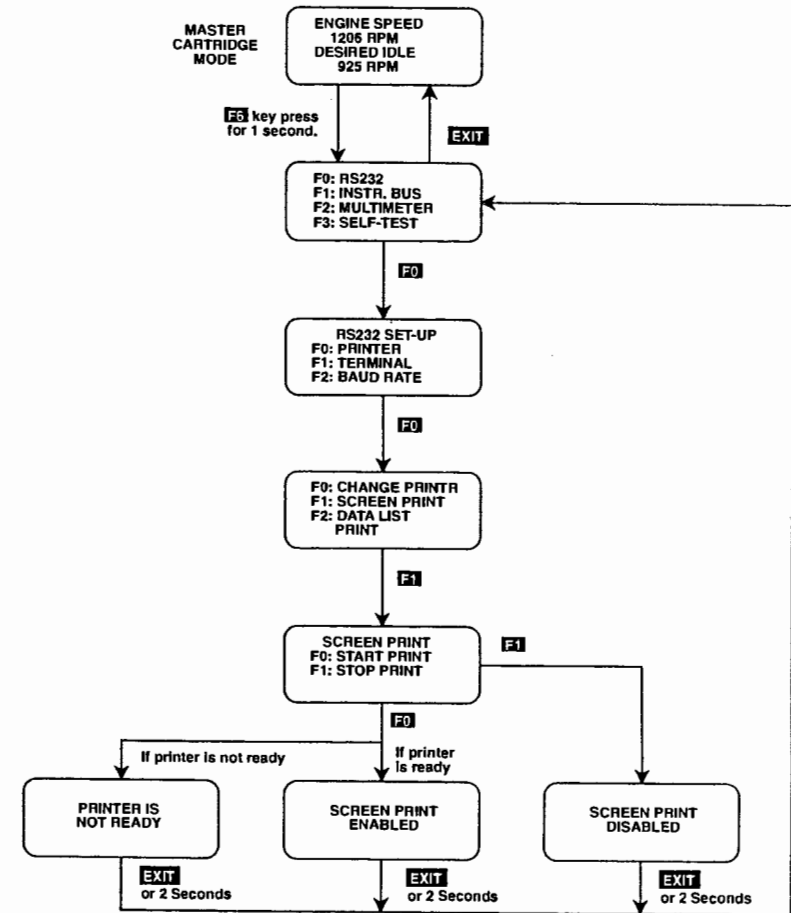

SCREEN PRINT FUNCTION

F0: PRINTER

F1: SCREEN PRINT

SCREEN PRINT

When the **TECH 1A** and printer are set to operate in the Screen Print mode, the printer makes a copy of the display when the information on the **TECH 1A** screen changes. This function allows you to make a permanent record of trouble codes or test results, or to save vehicle data for further analysis. You can use Screen Print to print portions of the Snapshot data in a tabular format so that you can look for abnormal conditions.

Many **TECH 1A** screens contain information for which printing is of little or no value, such as the engine selection process and the mode selection menus. Therefore, printing of these screens is generally not available even when the Screen Print mode is enabled.

The Screen Print displays are printed in one of three formats:

1. Two Column Tabular Print
2. Double Wide Red Print *
3. Double Wide Black Print*

* Double wide and red print are available only when using the **TECH 1** Printer.

F0: PRINTER

F1: SCREEN PRINT

TWO COLUMN TABULAR PRINT

The tabular print format is used when the **TECH 1A** is displaying Data List data (Data List or Snapshot mode). In this print format, the parameter descriptors displayed on lines 1 and 3 of the **TECH 1A** are not printed unless they change. The data from line 2 is printed in column 1 while the data from line 4 is printed in column 2 whenever anything in the display changes. Generally only 1 line is printed when data changes. This print format allows you to print a table consisting of any two Data List parameters you want to print. Remember that you can create your own data pairs by pressing **F0** or **F1** to "fix" the top or bottom parameter respectively (refer to the master cartridge operator's manual). Parameter pairs that you select can easily be changed while in the Screen Print mode.

DOUBLE WIDE RED PRINT

When Trouble Codes are being displayed, the **TECH 1A** will automatically print them in a double wide red print format if you are using a **TECH 1** Printer. This allows you to readily identify the Trouble Codes when you are looking at the print-out.

DOUBLE WIDE BLACK PRINT

All other screens printed when the Screen Print mode is enabled are printed in the double wide black print format.

F0: PRINTER

F1: SCREEN PRINT

F0: PRINTER

F2: DATA LIST PRINT

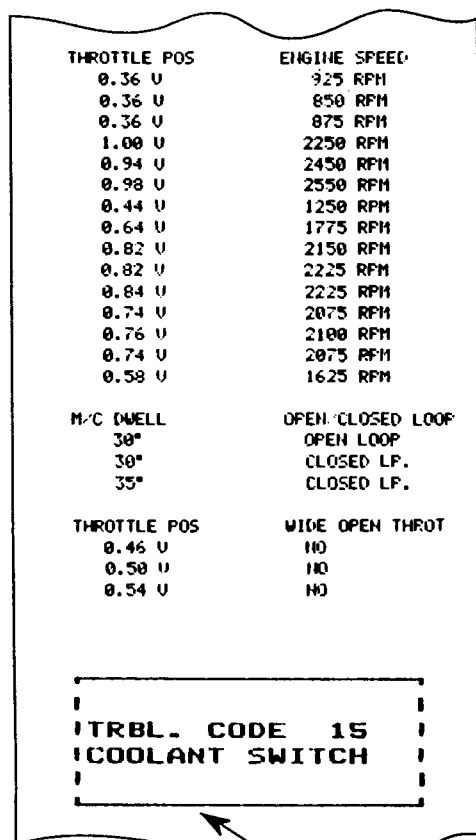

Double Wide
Print (red)

"SCREEN PRINT" PRINT-OUT

Tabular
Print

TECH 1A DISPLAY

THROTTLE POS
0.74 V
ENGINE SPEED
2075 RPM

when
data only
changes

THROTTLE POS
0.58 V
ENGINE SPEED
1625 RPM

when new
parameters
are
selected

M/C DWELL
30°
OPEN/CLOSED LOOP
OPEN LOOP

The **TECH 1A** is initially set up to print the entire Data List, using a **TECH 1** printer, whenever the **F8** key is pressed while in the Data List or Snapshot mode. If you want to print specially selected data, you must specify these by using the Data List Print set-up function. This function allows you to print all Data List parameters, or select only those parameters that you wish to be printed.

OPERATING PROCEDURE

1. Before the Data List Print mode can be set up, you must enter the Data List or Snapshot mode. Follow the procedures described in the manual for the master cartridge you are using.

If the **TECH 1A** is operating with a master cartridge installed, press the **F6** key for approximately 1 second to display the Onboard Functions menu.

If the **TECH 1A** is operating in Stand-alone mode, press **EXIT** until the Onboard Functions menu is displayed.

2. From the Onboard Functions menu, press **F0** to reveal the RS232 Set-up menu.

3. From the RS232 Set-up menu press **F0** to display the Printer menu.

4. Press **F2** to enter the DATA LIST PRINT set-up mode. The **TECH 1A** will display a screen asking you to select the Data List parameters that you wish to be printed when the **F8** key is pressed.

F0: PRINTER

F2: DATA LIST PRINT

5. Three options are displayed for setting up the Data List Print feature:

F0: PRINT ALL DATA

If you choose F0: PRINT ALL DATA, the TECH 1A returns to the Data List display. When **F3** is pressed, the entire Data List is printed.

F1: SELECT NEW SET OF DATA

If you press **F1**, the TECH 1A instructs you to press **↑** or **↓** to scroll through the Data List parameters. When a parameter is displayed that you wish to print, press the **YES** key. *****PRINT IT***** is displayed on line 2 and the number of parameters selected is displayed at the end of line 3. Use the **↑** or **↓** keys to continue scrolling through the Data List parameters. To remove a parameter from the list, press **NO** when the parameter is displayed.

F2: EDIT LAST SET OF DATA

If you have previously selected a set of data parameters to be printed, you can use F1: EDIT LAST to change the parameters. Just press **YES** when a parameter you want printed is displayed or press **NO** to remove a previously selected parameter.

6. Once you have selected the parameters you want printed, press **ENTER** to return to normal TECH 1A operation. If you want to start over, press **EXIT** to go to the Data Select menu.

7. To modify the list of parameters that you selected, repeat Steps 1-5 and select the F2: EDIT DATA option.

F0: PRINTER

F2: DATA LIST PRINT

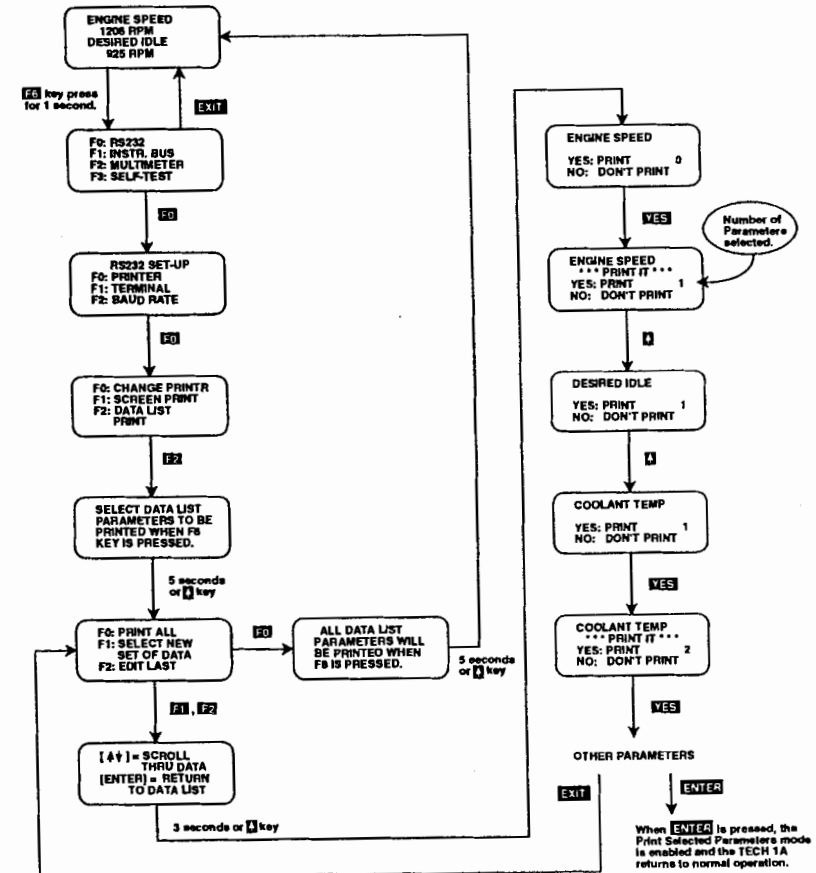

F0: PRINTER

F2: DATA LIST PRINT

DATA LIST PRINT

The purpose of the Data List Print feature is to provide a permanent record of data. Data List Print is easy to use; all you do is press the **F8** key when you are in the Data List or Snapshot mode of operation of the master cartridge, and the **TECH 1A** prints Data List parameters.

If you have not performed the Data List Print set-up procedure or if you selected "PRINT ALL", the **TECH 1A** will print all of the Data List parameters. The order of the parameters is the same as they appear when you sequence through the parameters using the **YES** key in the Data List mode.

By using the F2: DATA LIST PRINT operating procedure you can modify this setting so that only the parameters which you select are printed when the **F8** key is pressed.

Some parameters (e.g. ENGINE SPEED) may appear more than once in the Data List (multiple pairs). If you select those parameters more than once, they will be repeated in the print-out.

The following page shows two examples of the Data List print-out of data captured during a Snapshot test. The first example shows the complete list of Data List parameters, while the second example is a print-out after the **TECH 1A** was set up to print six parameters.

Not all master cartridges support the Data List Print feature. If the cartridge you are using does not support it, the **F8** key press will be ignored. The **F8** key will also be ignored if you are not in the Data List or Snapshot mode of operation of the master cartridge.

F0: PRINTER

F2: DATA LIST PRINT

TECH 1 SNAPSHOT DATA -2

1. VEHICLE SPEED	0 MPH
2. ENGINE SPEED	1325 RPM
3. BATTERY VOLTAGE	14.2 U
4. COOLANT TEMP	75°C 167°F
5. THROTTLE POS	0.28 U
6. M/C DWELL	23°
7. EXHAUST RECIRC.	0 %
8. OXYGEN SENSOR	448 mV
9. O2 CROSS COUNTS	3
10. ESC	7.4
11. BARO (KPa, U)	100 4.64
12. MAP (KPa, U)	64 4.04
13. PROM ID	6471
14. RICH OR LEAN	LEAN
15. OPEN/CLOSED LOOP	OPEN LOOP
16. WIDE OPEN THROT	NO
17. WOT DIVERT	OFF
18. ISC HOSE SWITCH	OPEN
19. IDLE SPEED CTRL.	REVERSE
20. AIR SWITCH SOL	OFF
21. AIR DIVERT SOL	ON
22. THROTTLE KICKER	ON
23. BLENDED ENRICH.	OFF
24. E-CELL	EXPIRED
25. P/N SWITCH	-R-DL
26. 3RD GEAR SWITCH	ON
27. HIGH GEAR SWITCH	ON
28. TCC SOLENOID	OFF
29. A/C SOLENOID	OFF

Full
DATA LIST
Print-Out

TECH 1 SNAPSHOT DATA -2

1. VEHICLE SPEED	0 MPH
2. ENGINE SPEED	1325 RPM
3. COOLANT TEMP	75°C 167°F
4. THROTTLE POS	0.28 U
5. OXYGEN SENSOR	448 mV
6. MAP (KPa, U)	64 4.04

SNAPSHOT
Sample
Number

Print-Out
of Selected
DATA LIST
Parameters

"DATA LIST" PRINT-OUT

F1: TERMINAL

F0: CHANGE TERMINAL

The RS232 interface and the remote terminal must be set at the same baud rate for proper communication to occur. If the terminal selected does not perform correctly or displays garbage, confirm that the baud rate for the RS232 interface is set at the baud rate defined in the terminal manual. If the operator's manual for the terminal is not available, just try setting the RS232 interface at different baud rates until the display is correct. No damage to the **TECH 1A** or terminal will result from operating at the wrong baud rate. If you are using the **TECH 1A** default terminal (VT-100 WYSE 60), you do not need to perform this procedure.

OPERATING PROCEDURES:

1. If the **TECH 1A** is operating with a master cartridge installed, press the **F6** key for approximately 1 second to display the Onboard Functions menu.

If the **TECH 1A** is operating in Stand-alone mode, press **EXIT** until the Onboard Functions menu is displayed.

2. From the Onboard Functions menu, press **F0** to reveal the RS232 Set-up menu.
3. Press **F1**: TERMINAL from the RS232 Set-up menu.
4. Press **F0**: CHANGE TERMINAL from the Terminal menu. The terminal that is currently selected is indicated by "****".
5. Select **F0** for a WYSE 85 (VT-220) terminal or **F1** for a WYSE 60 (VT-100) terminal. The **TECH 1A** will remember which terminal you selected for up to 24 hours.
6. The **TECH 1A** displays the terminal you selected for 2 seconds, then returns to the Terminal menu. From this menu you can select the terminal operating mode.
7. From the Terminal menu, press **EXIT** to return to the Onboard Functions menu.

F1: TERMINAL

F0: CHANGE TERMINAL

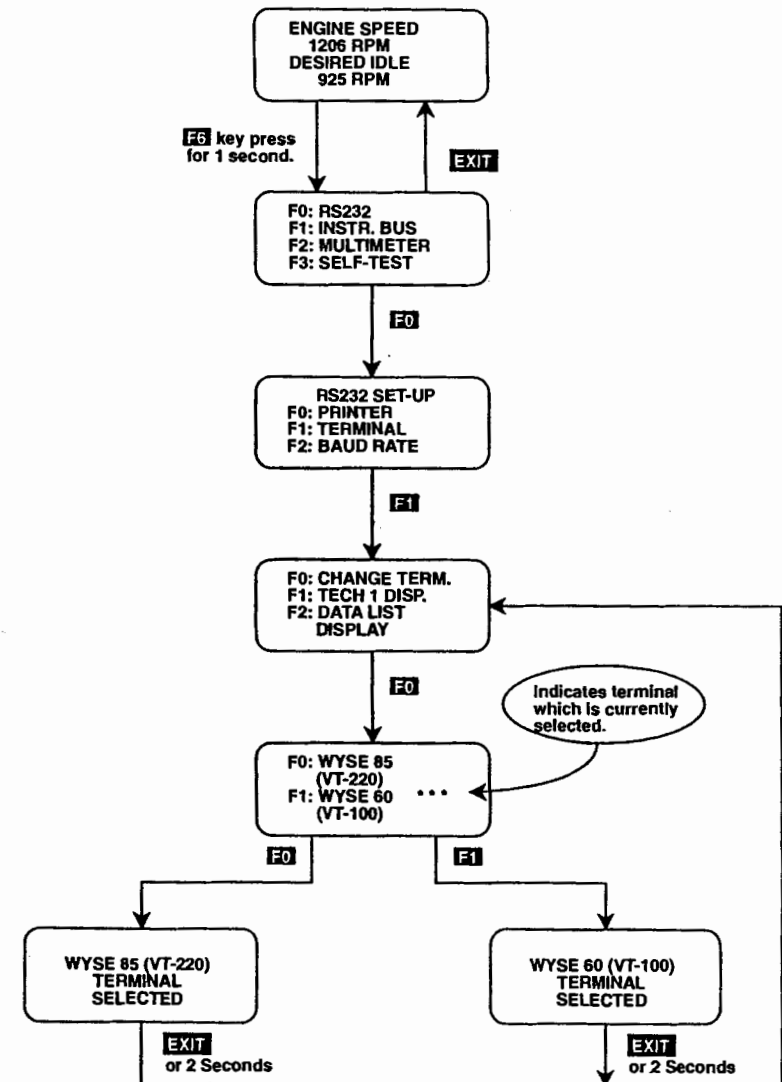

F1: TERMINAL

F1: TECH 1 DISPLAY

The **TECH 1** Display mode of operation allows you to use a terminal as a remote **TECH 1** display. In this mode, the same information which is displayed on the **TECH 1A** is displayed on the terminal in a double-high, double-wide display format.

OPERATING PROCEDURES:

1. If the **TECH 1A** is operating with a master cartridge installed, press the **F6** key for approximately 1 second to display the Onboard Functions menu.

If the **TECH 1A** is operating in Stand-alone mode, press **EXIT** until the Onboard Functions menu is displayed.

2. From the Onboard Functions menu, press **F0** to reveal the RS232 Set-up menu.

3. From the RS232 Set-up menu press **F1**: TERMINAL.

4. Press **F1**: **TECH 1 DISPLAY** from the Terminal menu to display data on the remote display. The **TECH 1A** display informs you that the **TECH 1** display has been enabled.

5. To turn the remote display OFF, simply **EXIT** from the RS232 Set-up menu without selecting the **TECH 1 DISPLAY** mode.

6. After 2 seconds or an **EXIT** key press the **TECH 1A** returns to the Onboard Functions menu. Press **EXIT** again to return to normal **TECH 1A** operation.

F1: TERMINAL

F1: TECH 1 DISPLAY

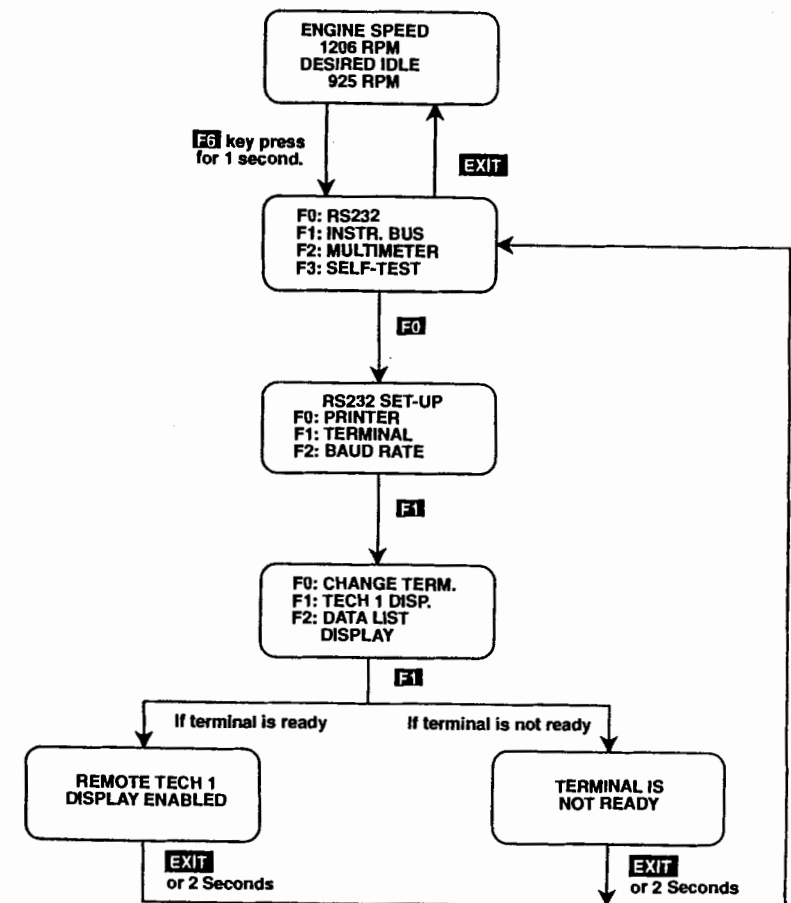

F1: TERMINAL**F2: DATA LIST DISPLAY**

7. If you selected ALL DATA LIST PARAMETERS, you must now choose between displaying the data in small characters (F0) or large characters (F1). If you select small characters (the standard characters used on the terminal), you will be able to display up to 50 Data List parameters simultaneously. With the large character format (double-high, double-wide), you can display a maximum of 12 parameters at one time. In either case, if there is more data than can be displayed at one time, pressing **F8** or **F9** will scroll through "pages" of data.

*The small character version of the Display All Parameters mode can be enabled directly from the Data List mode by pressing the **F9** key for approximately 1 second.*

8. If you opted to display SELECTED DATA LIST PARAMETERS, the **TECH 1A** will ask if you want to SELECT DATA TO DISPLAY (F0) or DISPLAY DATA previously selected (F1). If you press **F1**, the data will immediately be displayed on the terminal and the **TECH 1A** will return to normal operation.
9. If you pressed **F0** to SELECT DATA LIST PARAMETERS, you can select between modifying the last set of parameters you selected (F1: EDIT LAST SET OF DATA) or starting from scratch (F0: SELECT NEW SET OF DATA).
10. To make a new list of parameters or modify an existing list, press **F0** or **F1**, then use the **↑** and **↓** keys to sequence through the parameters. Press **YES** to select the parameters you want to display. Press **NO** if you change your mind. "****DISPLAY IT****" will be displayed under the parameters you have selected.

A count of the number of parameters you have selected is displayed on line 3 of the **TECH 1A**. A list of the selected parameters is also shown on the terminal. If you try to select more than 12 parameters, a "****TOO MANY****" message will be displayed on line 2 of the **TECH 1A**.

11. Once you have selected the parameters you want, press **ENTER** to display the selected Data List parameters. If you want to start over, press **EXIT** to go to the Select Data menu.

F1: TERMINAL**F2: DATA LIST DISPLAY**

1. ENGINE SPEED	2560 RPM	26. TCC SLIP	-10 RPM
2. DESIRED IDLE	925 RPM	27. CURRENT WEAK CYL	6
3. COOLANT TEMP	64°C 147°F	28. HISTORY WEAK CYL	6
4. MANI AIR TEMP	22°C 72°F	29. PURGE DUTY CYCLE	0%
5. THROT POSITION	4.44 VOLTS	30. BATTERY VOLTAGE	13.3 VOLTS
6. THROTTLE ANGLE	100%	31. A/C REQUEST	YES
7. MASS AIR FLOW	11.0 g/S	32. A/C CLUTCH	OFF
8. LV8 (ENG. LOAD)	7	33. A/C CLUTCH	OFF
9. OXYGEN SENSOR	146 mV	34. A/C HEAD PRESS.	OK
10. RICH/LEAN FLAG	LEAN	35. C/C BRAKE SWITCH	NO
11. O2 CROSS COUNTS	1	36. TCC BRAKE SWITCH	NO
12. AIR FUEL RATIO	12.23	37. C/C SET SPEED	0 MPH
13. ENGINE SPEED	2560 RPM	38. MPH KPH	10 16
14. SPARK ADVANCE	15°	39. DESIRED CRUISE	0%
15. FUEL INTEGRATOR	130	40. DESIRED FEEDBACK	0%
16. BLOCK LEARN	119	41. CRUISE MODE	OFF
17. OPEN/CLOSED LOOP	OPEN LOOP	42. C/C SERVO POS.	4
18. BLOCK LEARN CELL	4 CELL	43. C/C BRAKE SWITCH	NO
19. KNOCK RETARD	0°	44. C/C ON/OFF SW	ON
20. KNOCK SIGNAL	NO	45. C/C RES/ACCEL SW	OFF
21. IDLE AIR CONTROL	109	46. C/C SET/CST SW	OFF
22. PARK/NEUTRAL	-R-DL	47. C/C VAC UUM SOL	OFF
23. MPH KPH	10 16	48. C/C VENT SOL	ON
24. TCC MODE	OFF	49. P A (PRNDL)	HI
25. TCC DUTY CYCLE	0%	50. B C (PRNDL)	LO HI

**TERMINAL MODE DATA LIST DISPLAY
(SMALL CHARACTERS)**

ENGINE SPEED	2560 RPM
DESIRED IDLE	925 RPM
COOLANT TEMP	64°C 147°F
MANI AIR TEMP	22°C 72°F
THROT POSITION	4.44 VOLTS
THROTTLE ANGLE	100%
MASS AIR FLOW	11.0 g/S
LV8 (ENG. LOAD)	7
OXYGEN SENSOR	146 mV
RICH/LEAN FLAG	LEAN
O2 CROSS COUNTS	1
AIR FUEL RATIO	12.23

**TERMINAL MODE DATA LIST DISPLAY
(LARGE CHARACTERS)**

F2: BAUD RATE SELECTION

CHANGING THE RS232 BAUD RATE

The "baud rate" determines how fast data is transferred between the **TECH 1A** and the printer, terminal, or computer connected to it. The RS232 interface allows you to set the baud rate to be compatible with the equipment you are using. When you turn the **TECH 1A** on, the baud rate defaults to 9600 bits/second (or to the baud rate at which it was last set if the **TECH 1A** has not been disconnected from a power source for too long). The port for the RS232 interface is a 10-pin RJ45 connector located on the left side of the **TECH 1A**.

You must make sure that the **TECH 1A** baud rate is consistent with the device which it is connected to. Most devices which you will be using are set up for 9600 bits/second, and you will not need to use this function. If you have a device which is not 9600 bps, the recommended approach is to change the device's default setting to 9600 bps, eliminating the need to regularly change the **TECH 1A**'s baud rate.

OPERATING PROCEDURES:

1. If the **TECH 1A** is operating with a master cartridge installed, press the **F6** key for approximately 1 second to display the Onboard Functions menu.

If the **TECH 1A** is operating in Stand-alone mode, press **EXIT** until the Onboard Functions menu is displayed.

2. From the Onboard Functions menu, press **F0** to reveal the RS232 Set-up menu.
3. Press **F2** to select the BAUD RATE selection option. The **TECH 1A** will display a screen showing you the current baud rate selection.
4. Press the **↑** key to increase the baud rate or **↓** to decrease the baud rate. The new baud rate will be displayed. All standard baud rates from 300 bits/second to 19,200 bits/second are available.
5. Pressing **EXIT** will save the baud rate which is displayed and will return you to the Onboard Functions menu. **The TECH 1A will remember which baud rate you selected for up to 24 hours.** Press **EXIT** again to restore normal **TECH 1A** operation.

F2: BAUD RATE SELECTION

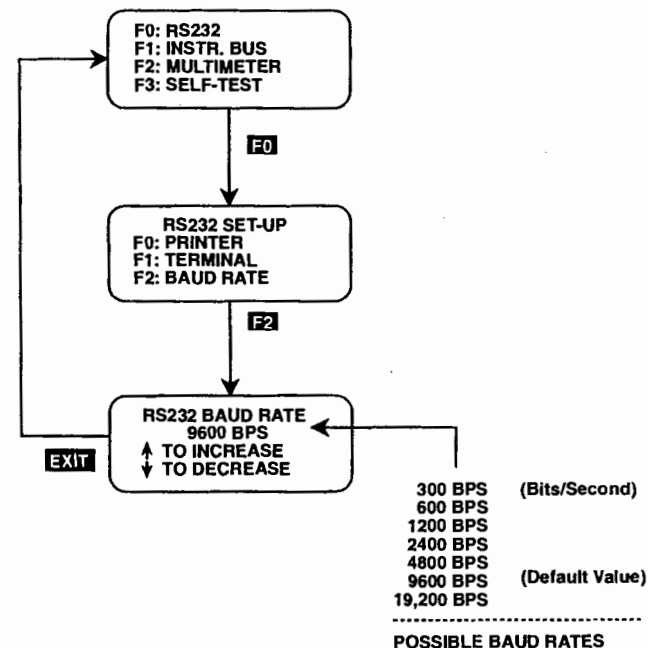

BAUD RATE SELECTION

5.0 SELECTING AND OPERATING INSTRUMENTATION PORT FUNCTIONS

The **TECH 1A** Instrumentation Port supports two modes of operation: Instrumentation Bus (I/B) and Multimeter. A brief description of each mode is given below. Detailed operating instructions are included in the following pages.

The Instrumentation Port consists of a 10-pin RJ45 "Phone Plug" connector on the right side of the **TECH 1A**.

The 10-pin RJ45 connector for instrumentation port devices is "keyed" so that it will fit into the instrumentation port on the right side of the **TECH 1A**, but it will not fit into the RS232 port on the left side.

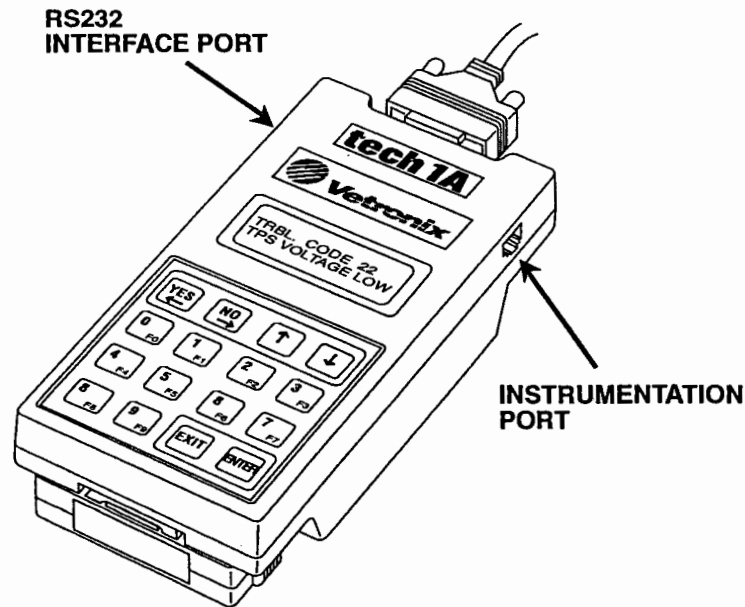

INSTRUMENTATION BUS

The Instrumentation Bus mode can be used to connect the **TECH 1A** to one or more "smart" diagnostic components. This allows the **TECH 1A** to act as a "Diagnostic System Controller" for an integrated diagnostic testing system.

For further information, see the Operator's Manual provided with the Instrumentation Bus component(s) you wish to use.

MULTIMETER

The built-in Multimeter function lets you use the **TECH 1A** Instrumentation Port to capture vital diagnostic data. With the **TECH 1A** test lead you can measure:

- DC voltage
- frequency
- pulse width
- duty cycle
- period

Included in your **TECH 1A** kit is a test lead to use with the Instrumentation Port while making Multimeter measurements.

This meter is not intended for diagnosis requiring precision measurements, or for circuits with high impedance. DO NOT USE THIS METER FOR OXYGEN SENSOR CIRCUIT DIAGNOSIS, AS IT MAY ALTER NORMAL OXYGEN SENSOR BIAS AND OPERATING VOLTAGE LEVELS.



CAUTION

Personal injury or damage to the **TECH 1A** may result if the test lead is used to check voltages higher than 30 volts (e.g. standard AC wall outlet). Also, the test lead should be kept away from high tension secondary ignition wires when the engine is cranking or running.

F1: INSTRUMENTATION BUS

The Instrumentation Bus mode allows you to set up the **TECH 1A** for use with selected instrumentation bus devices that you wish to use.

Results of the Instrumentation Bus tests can be printed by activating the Screen Print mode at power-up, or by pressing the **F6** key for 1 second when operating the **TECH 1A** with a master cartridge installed. Screen Print mode set-up is explained in Section 4.

The baud rate for devices connected to the Instrumentation Bus is automatically matched by the **TECH 1A**.

OPERATING PROCEDURES:

1. Connect the Instrumentation Bus cable to the 10-pin RJ45 jack on the right side of the **TECH 1A**.
2. Follow the instructions supplied with the instrumentation device you are using to connect it to the **TECH 1A** Instrumentation Bus. Turn the instrument ON.
3. The Onboard Functions menu is displayed when the **TECH 1A** is powered up with no master cartridge installed, or by pressing the **F6** key for 1 second if the **TECH 1A** is operating with a master cartridge installed.
4. From the Onboard Functions menu Press **F1** to select the Instrumentation Bus.
5. Devices connected to the Instrumentation Bus are sequentially displayed on the **TECH 1A** screen. Press **NO** until the device you wish to use is displayed, then press **YES**. At this point **TECH 1A** operation depends on the Instrumentation Bus device you selected. Refer to the Operator's Manual for the device you selected.

The **TECH 1A** will inform you if no devices are detected on the instrumentation bus.

6. Once you've selected an Instrumentation Bus device, follow the instructions supplied with the device to select a different device. Usually you only need to press **EXIT** until "SELECT DEVICE" is displayed, then select the device you wish to use.

F1: INSTRUMENTATION BUS

7. Press **EXIT** to return to the Onboard Functions menu from the "SELECT DEVICE" display.

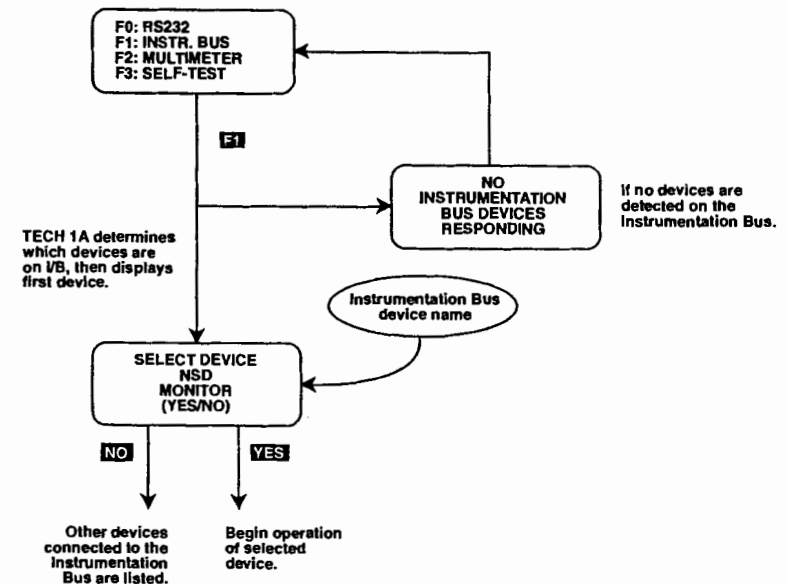

INSTRUMENTATION BUS

F2: MULTIMETER

F2: MULTIMETER

The instructions in this section are for the **TECH 1** test lead included in the **TECH 1A** kit. If you are using a different test instrument, follow the operating instructions supplied with the instrument.

Multimeter test results can be printed by enabling the RS232 Screen Print mode. Screen Print mode set-up is explained in Section 4. Once Screen Print is enabled, the current screen will be printed whenever the **ENTER** key is pressed. Pressing **ENTER** also freezes and unfreezes the currently displayed measurement value on the **TECH 1A** screen.

When the **TECH 1A** is operating in one of the multimeter modes, the **F0** - **F2** keys are active. This allows you to quickly select a different Multimeter mode. For instance, if you are in the Voltmeter mode, pressing **F2** activates the Pulse Width mode.

When the **TECH 1A** is operating with a master cartridge to collect Snapshot data and a Multimeter mode is also active, you can manually trigger the Snapshot by pressing **F9**.

MULTIMETER SPECIFICATIONS

Voltmeter Accuracy	DC Voltage 4% + 0.1V
Voltmeter Input Impedance	1 MΩ @ 0-5V 286 KΩ @ 5-20V
Voltage Range	0.0V - 20.0V
Frequency Meter Input Impedance	1 MΩ
Frequency Range	1 Hz - 2.5 KHz @ 50% Duty Cycle
Pulse Width Range	150 μS - 999 mS

OPERATING PROCEDURES:

1. Connect the test cable to the 10-pin RJ45 jack on the right side of the **TECH 1A**.

*To establish a ground reference, you must connect the **TECH 1A** DLC cable to the vehicle diagnostic connector. Otherwise the voltmeter display will be lower than the actual voltage by about 0.5 V and the frequency/pulse width measurements may be invalid.*

2. The Onboard Functions menu is displayed when the **TECH 1A** is powered up with no master cartridge installed, or by pressing the **F6** key for 1 second if the **TECH 1A** is operating with a master cartridge.
3. From the Onboard Functions menu press **F2** to select the Multimeter modes menu. A reminder to connect the **TECH 1A** DLC cable to the vehicle diagnostic connector is displayed. Confirm that the cable is connected, then press **YES**.

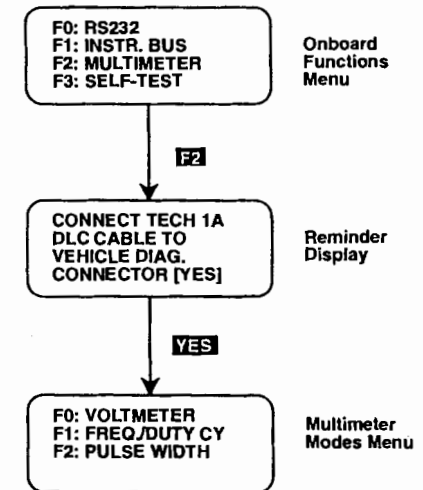

F2: MULTIMETER

F0: VOLTMETER

4. VOLTMETER MODE

To select the Voltmeter function, Press **F0** from the Multimeter modes menu. The free-running voltage is displayed on line 1 and the maximum and minimum voltages recorded are displayed on line 3. The voltage range is 0.0V - 20.0V DC with 0.1V resolution.

This meter is not intended for diagnosis requiring precision measurements, or for circuits with high impedance. DO NOT USE THIS METER FOR OXYGEN SENSOR CIRCUIT DIAGNOSIS, AS IT MAY ALTER NORMAL OXYGEN SENSOR BIAS AND OPERATING VOLTAGE LEVELS.



CAUTION

Personal injury or damage to the TECH 1A may result if the test lead is used to check voltages higher than 30 volts (e.g. standard AC wall outlet). Also, the test lead should be kept away from high tension secondary ignition wires when the engine is cranking or running.

Press the **↓** key to reset the maximum and minimum voltage values.

Press **ENTER** to freeze the currently displayed measurement value. "**** FREEZE ****" is displayed on line 4 of the **TECH 1A** display until **ENTER** is pressed again to restore free running operation.

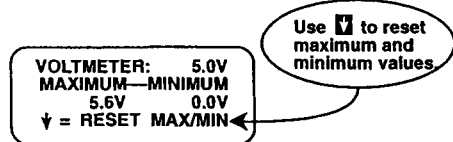

Sample Voltmeter Display

The **TECH 1A** buzzer will sound briefly each time the voltage changes 2.0V or more. You can use this function to help detect faults during "wiggle" testing, or to indicate change of state of switches and actuators.

Press **EXIT** to return to the Multimeter menu.

F2: MULTIMETER

F0: VOLTMETER

VOLTMETER SPECIFICATIONS

Voltmeter Accuracy DC Voltage 4% + 0.1V
Voltmeter Input Impedance 1 MΩ @ 0-5V Range
286 KΩ @ 5-20V Range
Voltmeter Range 0.0V - 20.0V
For precise measurements a DVOM should be used.

F2: MULTIMETER

F1:FREQUENCY/DUTY CYCLE

5. FREQUENCY AND DUTY CYCLE MODE

Press **F1** from the Multimeter menu to measure and display Frequency, Period and Duty Cycle. The **TECH 1A** will display frequencies from 1 Hz to 2.5 kHz on line 1. Period in micro seconds is displayed on line 2, and the percentage of time the signal is low (duty cycle) is displayed on line 3.

In order for the TECH1A to measure frequency, period, duty cycle or pulse width, the voltage level of the signal being measured must change from greater than 1.5 volt to less than 1 volt.

Press **ENTER** to freeze the currently displayed measurement value. "**** FREEZE ****" is displayed on line 4 of the **TECH 1A** display until **ENTER** is pressed again to restore free running operation.

If a printer is connected to the **TECH 1A**, activating the freeze function will cause the current screen to be printed.

FREQ.: 1.33 kHz
PERIOD: 753 μ S
DUTY: 35% LOW

Sample Frequency/Period/Duty Cycle Display.

In the Frequency/Duty Cycle mode the buzzer will sound briefly when more than 1 second elapses without a signal ("flat line").

Press **EXIT** to return to the Multimeter menu.

FREQUENCY/PERIOD/DUTY CYCLE

Frequency Range 1 Hz - 2.5 KHz
@ 50% Duty Cycle

F2: MULTIMETER

F2: PULSE WIDTH

6. PULSE WIDTH MODE

Press **F2** from the Multimeter menu to enter the Pulse Width test mode.

In the Pulse Width test the Pulse Width High time and Pulse Width Low time are displayed on lines 2 and 3, along with pulse widths from 200 μ Sec to 999 mSec (almost one second). The percentage of time the signal is low (duty cycle) is displayed on line 4.

In order for the TECH 1A to measure frequency, period, duty cycle or pulse width, the voltage level of the signal being measured must change from greater than 1.5 volt to less than 1 volt.

Press **ENTER** to freeze the currently displayed measurement value. "**** FREEZE ****" is displayed on line 4 of the **TECH 1A** display until **ENTER** is pressed again to restore free running operation.

If a printer is connected to the **TECH 1A**, activating the freeze function will cause the current screen to be printed.

PULSE WIDTH
HIGH: 489 μ S
LOW: 263 μ S
DUTY: 35% LOW

Sample Pulse Width display.

In the Pulse Width mode the buzzer will sound briefly when more than 1 second elapses without a signal ("flat line").

Press **EXIT** to return to the Multimeter menu.

FREQUENCY/PERIOD/DUTY CYCLE

Pulse Width Range 200 μ S - 999 mS

F2: MULTIMETER

F2: PULSE WIDTH

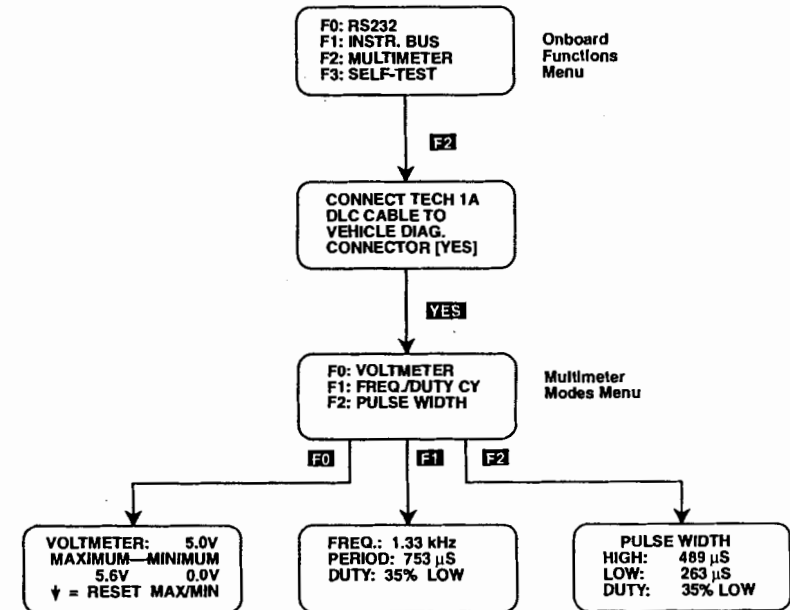

ACTIVE TECH 1 KEYS

- F0** Select Voltmeter mode.
- F1** Select Frequency/Duty Cycle mode.
- F2** Select Pulse Width mode.
- F9** Manual Snapshot trigger.
- ↓** Voltmeter mode: Reset maximum and minimum values.
- ENTER** Freeze currently displayed measurement values.

6.0 FINISHING UP

After using the **TECH 1A**, a few simple steps will insure that you get the most life out of your diagnostic tool.

1. Confirm that the vehicle's ignition is OFF.
2. Disconnect the **TECH 1A** cables.
3. If the **TECH 1A** is powered by the cigarette lighter, disconnect the cigarette lighter plug.
4. Unplug the cartridge and store the **TECH 1A**, cartridge, cables and vehicle adapter in the storage case.

NOTICE:

If the **TECH 1A** should become dirty, you may clean it with a mild detergent or hand soap. Avoid using harsh petroleum based cleaning solvents such as Acetone, Benzene and Trichloroethylene.

*Although the **TECH 1A** is water resistant, it is not waterproof, so be sure to thoroughly dry off your **TECH 1A** prior to storage. Do not submerge the **TECH 1A** in water.*

7.0 TECH 1A SPECIFICATIONS

DIMENSIONS: 3.75 x 8.0 x 1.875 inches

WEIGHT: 1.5 lbs.

OPERATING VOLTAGE: 5.5 to 25 vdc, reverse polarity protection

CURRENT DRAIN: 0.1 amp at 12 vdc

OPERATING TEMPERATURE: 0 to 100°F

STORAGE TEMPERATURE: 0 to 130°F

DISPLAY: 4 line, 16 characters liquid crystal backlit display (LCD)

KEYBOARD: 16 key, membrane with tactile feel

DATA RETENTION: up to 24 hours after removal of power.

DIAGNOSTIC PROGRAMS: individual, pluggable application cartridges

8.0 IF YOU'RE HAVING A PROBLEM... TECH 1A CAN TEST ITSELF

If you're having a problem with the operation of the **TECH 1A**, the Self-test can isolate the problem for you.

If the **TECH 1A** appears to be operating properly but data is not being received from the vehicle, disconnect the diagnostic connector, inspect the contacts and clean if necessary, then reconnect the diagnostic connector and try again. If after trying several times data is still not being received, or if the **TECH 1A** does not seem to operate properly, you can follow the operating procedure on page 8-2 to perform the **TECH 1A** Self-test.

The **TECH 1A** Self-test can check all internal **TECH 1A** circuits, auxiliary cartridges, the **TECH 1A** cable, the RS232 port, and the Instrumentation port to determine if they are operating properly. All Self-tests must be performed without a master cartridge installed.

If the **TECH 1A** does not pass all of the tests, you should:

- Check that the cable is securely attached to the **TECH 1A**
- Check that the **TECH 1A** DLC cable connector pins are clean
- Double check that the appropriate Test Adapter (required for certain tests) is properly installed and making good contact during the testing.

If the **TECH 1A** continues to fail the test and does not operate properly on another vehicle, call your **TECH 1** representative.

TECH 1A SELF-TEST OPERATING PROCEDURE

1. Disconnect the **TECH 1A** DLC cable from the vehicle and unplug the power cable from the cigarette lighter socket.
2. Verify that the **TECH 1A** cable is securely connected to the top of the **TECH 1A**. Remove any vehicle adapter that may be attached to the **TECH 1A** cable.

DO NOT connect the TECH 1A DLC cable to the vehicle while the Self-test is being performed.

3. If you wish to test an auxiliary cartridge, install the cartridge into the auxiliary cartridge slot on the **TECH 1A**.
4. Apply power to the **TECH 1A** by inserting the power cable into the receptacle on the side of the **TECH 1A** or into the receptacle on the cable connector. Plug the cigarette lighter plug into the cigarette lighter socket.
5. The Onboard functions menu shown below is displayed. Press **F3** to select the **TECH 1A** Self-test.

F0: RS232
F1: INSTR. BUS
F2: MULTIMETER
F3: SELF-TEST

For the TECH 1A Onboard Functions, the menu and displays are in English unless you are using a master cartridge that supports TECH 1A Onboard Functions in multi-language displays. TECH 1A Self-tests displays are always in English.

6. Three menus of Self-test options automatically scroll on the **TECH 1A** screen. Press the **↑** or **↓** key to stop the automatic scrolling and manually control the display.
7. Pressing the function key to the left of the Self-test that you wish to perform will cause the test to commence.

If **F4**, **F6** or **F7** is selected, you are instructed to install the appropriate Self-test adapter. The Instrumentation Port and RS232 Self-test adapter plugs into either port on the sides of the **TECH 1A**, and the 14-Pin test adapter plugs into the end of the **TECH 1A** cable. When the adapter is installed, press the **YES** key. Detailed descriptions of the Self-tests are given on pages 8-4 to 8-7.

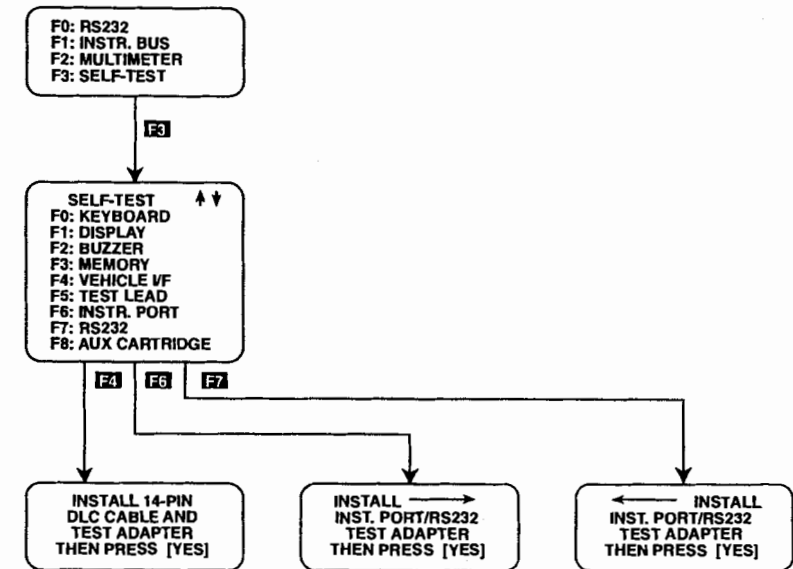

If an incorrect cable and test adapter are installed, or no adapter is installed, the test adapter prompt will be displayed.

If the Instrumentation Port/RS232 adapter is installed in the incorrect socket for the test requested, the adapter installation message is repeated with the flashing arrow indicating where the adapter should be installed.

8. Pressing **EXIT** while running a test stops the test and returns you to the Self-test menu. Pressing **EXIT** while the Self-test menu is displayed returns you to the Onboard functions menu.

TECH 1A SELF-TESTS

F0: KEYBOARD

This is a test for proper operation of the keyboard keys. Press each key to toggle it ON and OFF while you watch the display. If a key does not toggle, there is a keyboard malfunction. Press any key for 2 seconds to return to the Self-test menu.

F1: DISPLAY

In this test, the **TECH 1A** displays all possible characters so the technician can verify that the display is operating properly. In addition, one screen is displayed with all display elements turned on so that any bad display cells can be seen. Five different screens are each displayed for 2 seconds. The **↑** and **↓** keys may be used to freeze, then manually scroll these screens. Press **EXIT** to return to the Self-test menu.

F2: BUZZER TEST

When the BUZZER test is selected, the **TECH 1A** sounds the buzzer three times while displaying the current state. If there is no sound when "BUZZER ON" is displayed the buzzer is malfunctioning. The test automatically returns to the Self-test menu. **EXIT** may be pressed at any time to quit the test.

BUZZER ON

BUZZER OFF

F3: MEMORY

The Memory test verifies correct operation of the **TECH 1A** RAM, ROM, Gate Array, and CPU.

If all tests pass, the **TECH 1A** displays "TEST PASSED". Press **EXIT** to return to the Self-test menu.

If any test fails, fault codes for the failures are displayed until is pressed. A table of the fault codes is listed on page 8-8.

MEMORY
TEST IN PROGRESS
X SEC. REMAINING

Test in progress

MEMORY
TEST PASSED

All tests passed

FAULT CODES ↑↓
XX XX XX XX XX
XX XX XX XX XX
(SEE MANUAL)

Tests that failed

F4: VEHICLE I/F

The Vehicle Interface test checks the integrity of many of the critical circuits inside the **TECH 1A**.

If all tests pass, the **TECH 1A** displays "TEST PASSED". Press **EXIT** to return to the Self-test menu.

If any of the Vehicle Interface tests fail, fault codes for the failures are displayed until **EXIT** is pressed. If there is more than one page of fault codes, the **↑** and **↓** keys are used to scroll through the fault code displays. A table of the fault codes is listed on Page 8-8. If all the tests relating to the 14-pin test adapter fail, the "INSTALL TEST ADAPTER" prompt is redisplayed.

VEHICLE I/F
TEST IN PROGRESS
X SEC. REMAINING

Test in progress

VEHICLE I/F
TEST PASSED

All tests passed

FAULT CODES ↑↓
XX XX XX XX XX
XX XX XX XX XX
(SEE MANUAL)

Tests that failed

F5: TEST LEAD

This test verifies proper operation of the **TECH 1A** test lead. On entry to the test, the following screen is displayed.

HOLD TEST LEAD
AGAINST POSITIVE
BATTERY TERMINAL
THEN PRESS (YES)

Immediately after pressing **YES**, the screen will show one of two displays, the first if everything is in order, the second if the measured voltage is less than 6 volts:

TEST LEAD
TEST PASSED

TEST LEAD
TEST FAILED
VOLTS: X.X

Press **EXIT** to return to the Self-test menu.

F6: INSTRUMENTATION PORT

The Instrumentation Port/RS232 Self-test adapter must be installed in the Instrumentation Port connector on the right side of the unit to run this test.

This test checks for proper operation of the Instrumentation Port serial communications hardware.

If all tests pass, the **TECH 1A** displays "TEST PASSED". Press **EXIT** to return to the Self-test menu.

If any tests fail, a list of Fault Codes is displayed until the **EXIT** key is pressed. A table of the fault codes is listed on Page 8-8.

INSTR. PORT
TEST IN PROGRESS

Test in progress

INSTR. PORT
TEST PASSED

All tests passed

INSTR. PORT
FAULT CODES
XX XX
(SEE MANUAL)

Tests that failed

F7: RS232 TEST

The Instrumentation Port/RS232 Self-test adapter must be installed in the RS232 connector on the left side of the unit to run this test.

The RS232 test checks for proper operation of the RS232 serial data hardware.

If all tests pass, the **TECH 1A** displays "TEST PASSED". Press **EXIT** to return to the Self-test menu.

If any tests fail, a list of Fault Codes is displayed until the **EXIT** key is pressed. A table of the fault codes is listed on Page 8-8.

RS232
TEST IN PROGRESS

Test in progress

RS232
TEST PASSED

All tests passed

RS232
FAULT CODES
XX XX
(SEE MANUAL)

Tests that failed

F8: AUXILIARY CARTRIDGE

The **TECH 1A** performs a checksum validation on the Auxiliary cartridge EPROM, if present. The test is run once, then one of the three screens below is displayed indicating the results of the Auxiliary Cartridge checksum test.

If the cartridge fails the checksum test, it will need to be repaired (see Page 9-1). Line three of the "Checksum Passed" and "Checksum Failed" screens displays the identification number of the cartridge and the release date of the EPROM.

AUX. CARTRIDGE
CHECKSUM PASSED
ID: 45 8/17/90
[YES] = AUX TEST

Checksum passed

AUX. CARTRIDGE
CHECKSUM FAILED
ID: 45 8/17/90
[YES] = AUX TEST

Checksum failed

AUX. CARTRIDGE
NOT PRESENT

Auxiliary cartridge
is not installed

If **YES** is pressed and the auxiliary cartridge has Self-test capabilities, the cartridge will run its own Self-test program, taking control of the **TECH 1A** display and reporting the test status according to its own requirements.

If **YES** is pressed and the Auxiliary cartridge being tested does not contain a Self-test program, the following screen is displayed:

AUX. CARTRIDGE
SELF-TEST
NOT PRESENT

Press **EXIT** from any display to return to the Self-test menu.

TECH 1A SELF-TEST FAULT CODES

CODE	DESCRIPTION
01	CPU error
02	Gate Array register read/write error
03	CPU RAM error
04	Fixed RAM error
05	Auxiliary RAM error
06	Paged RAM error
07	Display register read/write error
08	Display ready flag timeout error
09	Resident EPROM checksum error
10	12V serial data error
11	5V serial data error
12	Differential serial data error
13	VIM serial data error
14	A to D conversion timeout error
15	CKENG input or Air Solenoid output error
16	VIM transmit or Input Capture error
17	DLC pins J/L/M, OD1/ODV, or A/D channels 1 and 7 error
18	10k ohm diagnostic enable error
19	3.9k ohm diagnostic enable error
20	Shorted diagnostic enable error
21	DATA+/DATA-, OD2, or A/D channel 8 error
22	RS232 Data Transmit/Receive error
23	RS232 handshake (RTS/CTS) error
24	Instr. Port data Transmit/Receive error
25	Instr. Port handshake (RTS/CTS) error
26	Diagnostic enable open bus error

9.0 WARRANTY AND REPAIR

WARRANTY

In the U.S. and Canada the **TECH 1A** is warranted to the original consumer to be free of defects in material and workmanship for a period of two years after the sale to the original consumer. Cartridges, cables, and adapters are warranted for a period of one year. If a unit is found to be defective, it will be repaired or replaced.

This warranty does not cover any part that has been abused, altered, used for a purpose other than that for which it was intended, or used in a manner inconsistent with instructions regarding use.

This warranty also excludes all incidental or consequential damages.

REPAIR SERVICE

If you suspect that you have a problem with your unit, read the operating instructions carefully to ensure that you are operating the unit properly. Avoid the inconvenience of returning a non-defective unit for repair. It is advisable to exercise the Self-test procedure outlined in this manual to ascertain if a problem exists.

If it is determined that a problem exists, package the tester, and cartridges along with all cables and adapters and send it to the repair service center listed for the country in which you live.

Please enclose a note which provides the date of purchase, brief explanation of the problem, and your return address. No C.O.D.s, please.

If the unit is determined to be in warranty, it will be repaired or replaced with no charge and returned freight prepaid.

If the Unit is determined to be out of warranty, it will be repaired for a nominal service charge plus return freight.

TECH 1A REPAIR SERVICE

USA

VETRONIX CORPORATION
2030 Alameda Padre Serra
Santa Barbara, CA 93103-1794
1-800-321-4889

CANADA

TECH 1 REPAIR SERVICE
c/o Custone Auto Radio LTD
1150 Champlain Court
Whitby, Ontario L1N 6A8

JAPAN

VETRONIX JAPAN CO. LTD.
Planning Building 2 F
2-2, 3 Chome Minamidai
Kawagoe-shi Saitama-ken
350 Japan
TEL (0492) 47-6481
FAX (0492) 47-6482

APPENDICES

- A. UNDERSTANDING RS232 COMMUNICATIONS
- B. IF YOU'RE HAVING A PROBLEM
- C. GLOSSARY AND ABBREVIATIONS

A. UNDERSTANDING RS232 COMMUNICATIONS

RS232 is a standard in the computer industry for serial communications between computers and peripheral devices. Virtually all small computer systems have at least one RS232 port. RS232 links are used to communicate with printers, display terminals, modems and many types of test equipment.

An RS232 communication link is a serial link as opposed to a parallel link. This means that data is transmitted serially, one bit after another, over a single data line versus a number of bits being transmitted simultaneously using multiple data lines as is done in a parallel link. Remember that the RS232 interface will not work with a device which uses a parallel interface. This is important since most printers connected to small computer systems are parallel printers and will not work with the **TECH 1A**.

Specifications for the RS232 link are provided on the following page. You should not need to use this information unless you are trying to set up the **TECH 1A** to interface to a device other than those discussed in this manual.

If you are trying to interface an RS232 compatible device to the **TECH 1A**, you must make sure that you set it up so that it can communicate with the **TECH 1A**. If you're having problems, refer to the specifications and use the following check list:

- Make sure the cable is connected
- Make sure the other device is "On Line"
- Make sure the baud rates are the same
- Make sure the data format is the same
- Make sure that the signals are connected appropriately between the two devices (the RS232 Transmit signal must be connected to the other device's Receive line and vice versa).

*An 8-pin RJ45 cable may be used with the **TECH 1A's** 10-pin connector. The cable's 8 pins will mate with the connector's pins 2 thru 9.*

RS232 V/F SIGNALS

PIN NUMBER	SIGNAL NAME	INPUT/OUTPUT	CONNECT TO:
1	NOT USED		
2	DTR	OUTPUT	DSR
3	CARRIER DETECT	INPUT	CARRIER DETECT
4	CTS	*	RTS
5	TRANSMIT	OUTPUT	RECEIVE
6	RECEIVE	INPUT	TRANSMIT
7	RTS	*	CTS
8	SIGNAL GROUND		SIGNAL GROUND
9	DSR	INPUT	DTR
10	NOT USED		

* CTS and RTS are connected together inside the **TECH 1A**, but are not used as handshake signals by the **TECH 1A**.

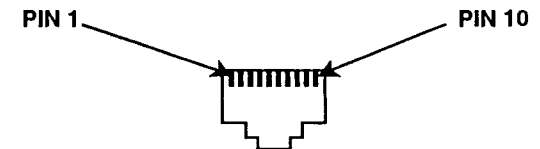

RS232 V/F CONNECTOR
(RJ45 10-PIN MODULAR PHONE JACK)

SIGNAL LEVELS:
LOGIC "1" - 9 V
LOGIC "0" +9 V

DATA FORMAT:
1 START BIT
8 DATA BITS
1 STOP BIT
NO PARITY

BAUD RATES:

SOFTWARE
SELECTABLE: 300 bps
600 bps
1200 bps
2400 bps
4800 bps
9600 bps
19200 bps

"RS232 V/F" SPECIFICATIONS

B. IF YOU'RE HAVING A PROBLEM

This section is intended to help you get back on track if the **TECH 1A** appears to be operating abnormally. Examples of most of the displays which you might see under abnormal conditions are shown. In addition, the most likely cause for the condition is given as well as other possible causes and recommendations on how to isolate or eliminate the problem.

1. SYMPTOM:

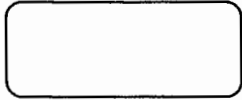

Blank screen when **TECH 1A** powered-up

MOST LIKELY CAUSES

- **TECH 1A** not receiving power from vehicle.
- Bad fuse in the **TECH 1A** power cord's cigarette lighter plug.
- Reverse polarity at cigarette lighter socket.

RECOMMENDATIONS

- Make sure that both the **TECH 1A** power plug and cigarette lighter socket have good clean contacts.
- Verify that the vehicle cigarette lighter has a good fuse.
- Verify that the fuse in the cigarette lighter plug on the **TECH 1A** power cord is good.
- Check that +12V power is present at the center contact of the lighter socket, and that the outside of the lighter socket is grounded. If the lighter socket has reverse polarity, either rewire the lighter socket or use a battery adapter cable to power the **TECH 1A**.

2. SYMPTOM:

F0: RS232
F1: INSTR. BUS
F2: MULTIMETER
F3: SELF-TEST

Onboard Functions menu displayed
when powering-up with a master cartridge installed

MOST LIKELY CAUSE

- **TECH 1A** not making good contact with cartridge.
- Cartridge is malfunctioning.

RECOMMENDATIONS

- Remove and re-insert cartridge making sure the cartridge is properly seated.
- Disconnect and reconnect the **TECH 1A** power plug.
- Try a different master cartridge.

3. SYMPTOM:



MOST LIKELY CAUSE:

- Printer is not turned ON or is OFF LINE.

OTHER POSSIBLE CAUSES:

- Printer out of paper.
- RS232 Cable not connected.
- Missing Printer Adapter Cable.
- Faulty RS232 Cable or Printer Adapter Cable.
- Printer and RS232 baud rates not the same.
- Cable not wired correctly (non-TECH 1 printer).
- Printer power supply inadequate (must be +12v at 3 amps).
- Printer malfunctioning.
- RS232 malfunctioning.

RECOMMENDATIONS:

- Make sure printer's green ON LINE indicator is on.
- Make sure printer has paper and that the red ALARM indicator is off.
- Make sure the 8' RS232 Cable is connected from the **TECH 1A** to the 3" Printer Adapter Cable. Make sure the 3" Cable is plugged into printer. (**Caution: Printer will not work if the RS232 Cable is plugged directly into the printer. The 3" Printer Adapter Cable must be used.**)
- Perform printer diagnostics by pressing the FEED button at the same time you turn the printer power on. The printer should print its full character set in both black and red.
- Run Self-Test on RS232 (Section 8).
- Check compatibility of printer and RS232 (refer to Appendix A).

4. SYMPTOM:

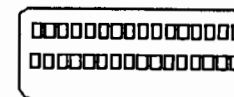

MOST LIKELY CAUSE:

- Master Cartridge was plugged in with power applied.

OTHER POSSIBLE CAUSES:

- Master cartridge is malfunctioning.
- RS232C I/F is malfunctioning.
- **TECH 1A** is malfunctioning.

RECOMMENDATIONS:

- Disconnect and reconnect power to **TECH 1A**.
- Try a different Master Cartridge.

5. SYMPTOM:

RS232 selection menu doesn't appear when **F6** held for 1 second.

POSSIBLE CAUSES:

- RS232 Interface malfunctioning.
- **TECH 1A** keyboard malfunctioning.

RECOMMENDATIONS:

- Disconnect and reconnect power to **TECH 1A**.
- Run Self-Test on RS232.
- Run Self-Test on **TECH 1A** keyboard.

6. SYMPTOM:

Wrong characters printed on printer.

MOST LIKELY CAUSE:

- Wrong printer selected.

OTHER POSSIBLE CAUSES:

- Printer which is not compatible with RS232.

RECOMMENDATIONS:

- Verify correct printer has been selected.
- Verify that a **TECH 1** Printer or IBM compatible serial printer is being used.

7. SYMPTOM:

Printer prints garbage continuously.

MOST LIKELY CAUSE:

- Incorrect Baud Rate.

OTHER POSSIBLE CAUSES:

- Master Cartridge was plugged in with power applied.

RECOMMENDATIONS:

- Cycle power on **TECH 1A**.
- Cycle power on printer.
- Verify that the proper Baud Rate has been selected.

C. GLOSSARY AND ABBREVIATIONS

ALDL	Assembly Line Diagnostic Link
Auxiliary Cartridge	A supplemental cartridge for the TECH 1A which is not required for the basic TECH 1A operation. The auxiliary cartridge plugs into the top slot of the TECH 1A .
Baud Rate	The speed at which data is transferred over a data link connector.
bps	Bits per second. Unit used for baud rate.
DLC	Data Link Connector
DATA LIST	A mode of operation available with most TECH 1 master cartridges. In the DATA LIST mode, basic diagnostic data parameters are displayed on the TECH 1A .
DATA LIST PRINT	A feature of the RS232 which allows you to print any combination of DATA LIST parameters when the TECH 1A is in the DATA LIST or SNAPSHOT mode.
DCE	Data Communication Equipment. A term used to describe a device connected to an RS232 link.
DTE	Data Terminal Equipment. A term used to describe a device connected to an RS232 link.
I/F	Interface.
Master Cartridge	A cartridge for the TECH 1A which is required for Master Cartridge mode of operation. The master cartridge plugs into the bottom slot of the TECH 1A .
Parallel Printer	A printer that communicates using a parallel interface where data is transferred one byte (8 bits) at a time. Parallel printers are not compatible with the RS232 I/F.

PRNTR	Printer
RS232	Same as RS232C.
RS232C	The most standard serial communication interface used in the computer industry.
SCREEN PRINT	An operating mode of the RS232 I/F where the TECH 1A display is output to a printer.
Serial Interface	A means of transferring data one bit at a time between devices.
Serial Printer	A printer that communicates using a serial interface where data is transferred one bit at a time.
SNAPSHOT	A mode of operation available with most TECH 1 master cartridges. In the SNAPSHOT mode, basic diagnostic data parameters are stored in the TECH 1A during a road test and can be examined, printed or transferred to a computer at the end of the test.
Y Adapter	An adapter cable for the TECH 1A which allows you to power both the TECH 1A and the TECH 1 Printer from a single cigarette lighter.